



E106-470G27P2 Usermanual



Content

1. Overview	2
1.1. Brief introduction	2
1.2. Main features	2
1.3. Block diagram	2
2. Interface description	3
2.1. Interface definition	3
2.2. Power interface	6
2.3. SPI interface	6
2.4. Control signal	7
2.4.1. PPS signal	7
2.4.2. NRESET signal	7
2.4.3. RX_ON signal	7
2.4.4. TX_ON signal	7
2.4.5. CFG_ON signal	7
2.4.6. TX_LED indicator light	7
2.4.7. RX_LED indicator light	7
3. Antenna interface	8
4. Electrical and RF performance of the interface	9
4.1. Power characteristics	9
4.2. IO interface characteristics	9
4.3. Working current	9
4.4. RF performance	9
5. Dimensions	11
6. Internal connection	12
7. Reference design	13
About us	错误! 未定义书签。

1. Overview

1.1. Brief introduction

E106-470G27P2 module is a LoRa gateway RF module designed based on the SX1302 chip. It adopts the standard Mini PCI-e package, SPI interface, the module has built-in PA and LNA, and the half-duplex design is convenient for users to quickly develop LoRa gateway equipment.

SX1302 is a new generation LoRa gateway baseband chip launched by Semtech. It is equipped with front-end SX1250 and can support spreading factors SF5~SF12. Compared with the previous generation SX1301 gateway solution, it can support higher-speed data communication, while the power consumption is greatly reduced, the design is simplified, and the performance is significantly improved.

1.2. Main features

- PCI Express Mini Card 1.2 standard interface;
- Sending current max 360mA, receiving current 60mA;
- I-PEX antenna interface, half-duplex communication;
- Standard SPI digital interface;
- Support 8 receiving channels, SF5~SF12 full solution, receiving sensitivity as low as -141dBm;
- Support 1 transmission channel, the maximum transmission power is 27dBm (typical value 26dBm);
- ISM band: EU433、CN470、EU868、US915.

1.3. Block diagram

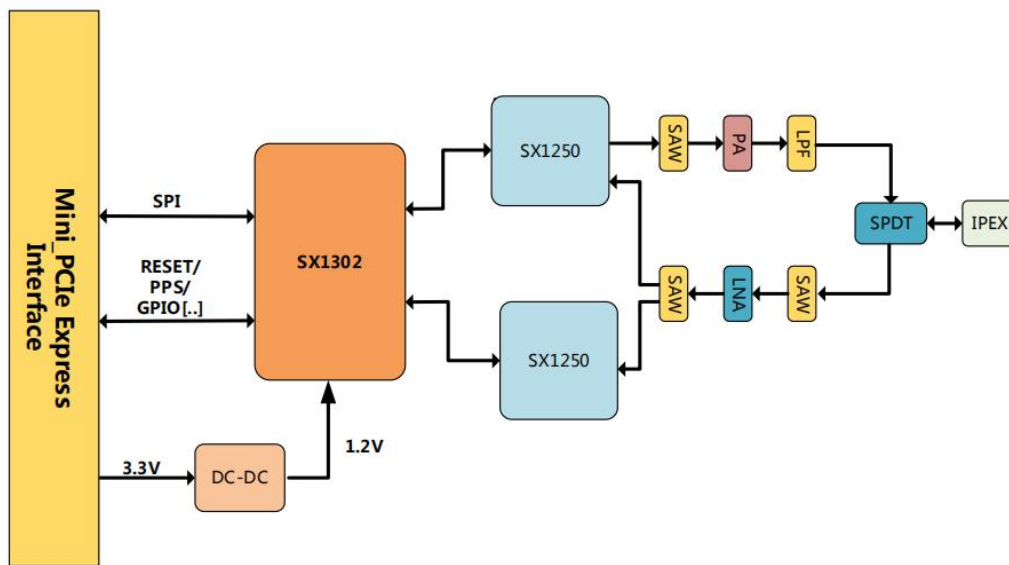

Figure 1: E106-470G27P2 function block diagram

2. Interface description

2.1. Interface definition

The signal interface of E106-470G27P2 is standard Mini PCI Express interface. The following table gives the function definition and description of the 52pin corresponding to the module.

Table 1: IO parameter definition

Attribute	Description
DI	Digital input
DO	Digital output
IO	Bidirectional input and output
PI	Power input

Table 2: Definition of main function pins

Pin	Pin No.
GND	4,9,15,18,21,26,27,29,34,35,37,40,43,50
3.3V	2,24,39,41,52
PPS	19
NRESET	22
RX_ON	42
TX_ON	44
CFG_ON	46
SX_SCK	45
SX_MISO	47
SX_MOSI	49
SX_CSN	51

Table 3: Detailed pin definition

No.	Mini PCIe definition	E106-xxxG27P2 definition	I/O attribute	Function description	Remark
1	WAKE#	RESERVED	DO	Use in transparent version, suspended	
2	3.3Vaux	VCC_3V3	PI	3.3V DC Main power input	
3	COEX1	NC	—	Internal use, suspended	
4	GND	GND	—	Ground	
5	COEX2	NC	—	Internal use, suspended	
6	1.5V	NC	—	Not used	
7	CLKREQ#	NC	—	Internal use, suspended	
8	UIM_PWR	NC	—	Not used	
9	GND	GND	—	Ground	
10	UIM_DATA	RESERVED	IO	Use in transparent version, suspended	
11	REFCLK-	RESERVED	DI	Use in transparent version, suspended	
12	UIM_CLK	RESERVED	IO	Use in transparent version, suspended	
13	REFCLK+	RESERVED	DO	Use in transparent version, suspended	
14	UIM_RESET	NC	—	Not used	
15	GND	GND	—	Ground	
16	UIM_VPP	NC	—	Internal use, suspended	
17	RESERVED	NC	—	Internal use, suspended	
18	GND	GND	—	Ground	
19	RESERVED	PPS	DI	GPS time input, can be suspended	
20	W_DISABLE#	NC	—	Internal use, suspended	
21	GND	GND	—	Ground	
22	PERST#	NRESET	DI	Reset control pin, valid in high level	
23	PERn0	RESERVED	DI	Reserved, externally suspended	
24	3.3Vaux	VCC_3V3	PI	3.3V DC Main power input	
25	PERp0	NC	—	Not used	
26	GND	GND	—	Ground	

27	GND	GND	—	Ground
28	1.5V	NC	—	Not used
29	GND	GND	—	Ground
30	SMB_CLK	NC	—	Internal use, suspended
31	PETn0	RESERVED	DO	Reserved, externally suspended
32	SMB_DATA	NC	—	Internal use, suspended
33	PETp0	NC	—	Not used
34	GND	GND	—	Ground
35	GND	GND	—	Ground
36	USB_D-	RESERVED	IO	Use in transparent version, suspended
37	GND	GND	—	Ground
38	USB_D+	RESERVED	IO	Use in transparent version, suspended
39	3.3Vaux	VCC_3V3	PI	3.3V DC Main power input
40	GND	GND	—	Ground
41	3.3Vaux	VCC_3V3	PI	3.3V DC Main power input
42	LED_WWAN#	RX_ON	DO	connected to the GPIO3 of SX1302.
43	GND	GND	—	Ground
44	LED_WLAN#	TX_ON	DO	connected to the GPIO5 of SX1302.
45	RESERVED	SX_SCK	DI	SPI clock signal input
46	LED_WPAN#	CFG_ON	DO	CFG indication, connect to onboard LE
47	RESERVED	SX_MISO	DO	SPI data output
48	1.5V	NC	—	Not used
49	RESERVED	SX_MOSI	DI	SPI data input
50	GND	GND	—	Ground
51	RESERVED	SX_CSN	DI	SPI chip select signal input
52	3.3Vaux	VCC_3V3	PI	3.3V DC Main power input

2.2. Power interface

Table 4: Power interface definition

Item	Pin No	IO Attribute	Function description
GND	4,9,15,18,21,26,27,29,34,35,37,40,43,50	—	—
3.3V	2,24,39,41,52	PI	3.3V power input

E106-470G27P2 module uses 3.3V power supply. In TX mode, the maximum instantaneous peak current may reach 400mA. In order to prevent voltage drop, the switch power supply or LDO used shall be able to provide enough current, and a tantalum capacitor or electrolytic capacitor with large capacitance value shall be added at the power supply port of the module. If switching power supply is used to supply power to the module, the circuit wiring shall avoid the antenna part as much as possible to prevent EMC interference.

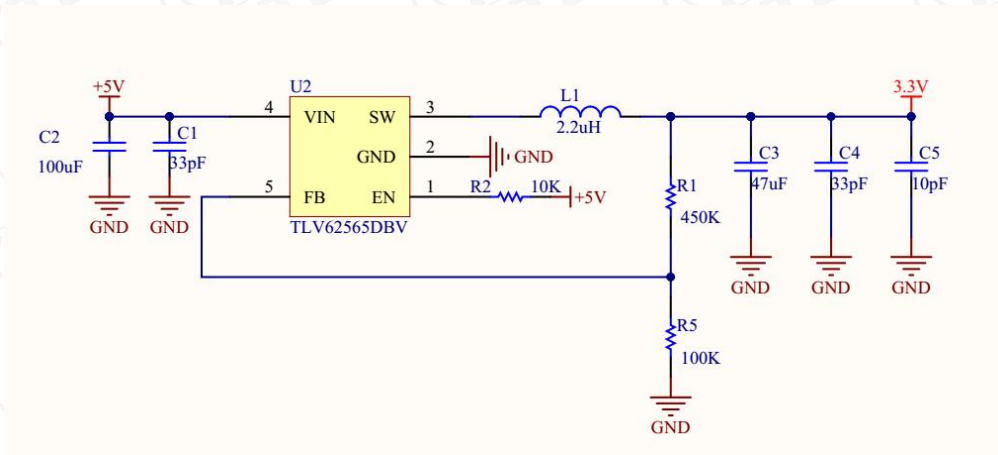

Figure 2: DC-DC reference circuit

2.3. SPI interface

The SPI interface signal definition of E106-470G27P2 module is shown in the following table.

Table 5: SPI interface signal definition

Item	Pin No.	I/O attribute	Description	Voltage
SX_SCK	45	DI	SPI clock signal input	3.3V
SX_MISO	47	DO	SPI data output	3.3V
SX_MOSI	49	DI	SPI data input	3.3V
SX_CSN	51	DI	SPI chip select signal input	3.3V

The master SPI needs to support full duplex. Please refer to the data sheet of SX1302 for the specific timing.

2.4. Control signal

Table 6: Control signal interface definition

Item	Pin No.	I/O attribute	Description	Voltage
PPS	11	DI	GPS time input	3.3V
NRESET	22	DI	Reset control pin	3.3V
RX_ON	42	DO	RX signal indication	3.3V
TX_ON	44	DO	TX signal indication	3.3V
CFG_ON	46	DO	CFG signal indication	3.3V

2.4.1. PPS signal

Supports GPS-PPS input for receiving time-stamped packets.

2.4.2. NRESET signal

The external control circuit can realize the reset of the module. Pull up the NRESET interface level for 0.05~0.2s and then release it to reset the module. The NRESET signal is sensitive to interference, and the wiring on the module interface board should be as short as possible, and it should be grounded.

2.4.3. RX_ON signal

connected to the GPIO3 of SX1302.

2.4.4. TX_ON signal

connected to the GPIO5 of the SX1302.

2.4.5. CFG_ON signal

When the module successfully configures the parameters, the pin outputs a high level, and the onboard LED lights up at the same time, and is connected to the GPIO of the SX1302.

2.4.6. TX_LED indicator light

The LED lights when the module is in the emission state.

2.4.7. RX_LED indicator light

The LED lights when the module is in the receiving state.

3. Antenna interface

The antenna connection base of the module adopts I-PEX 1 generation interface. Figure 3 shows the dimensions of the RF connector, in mm.

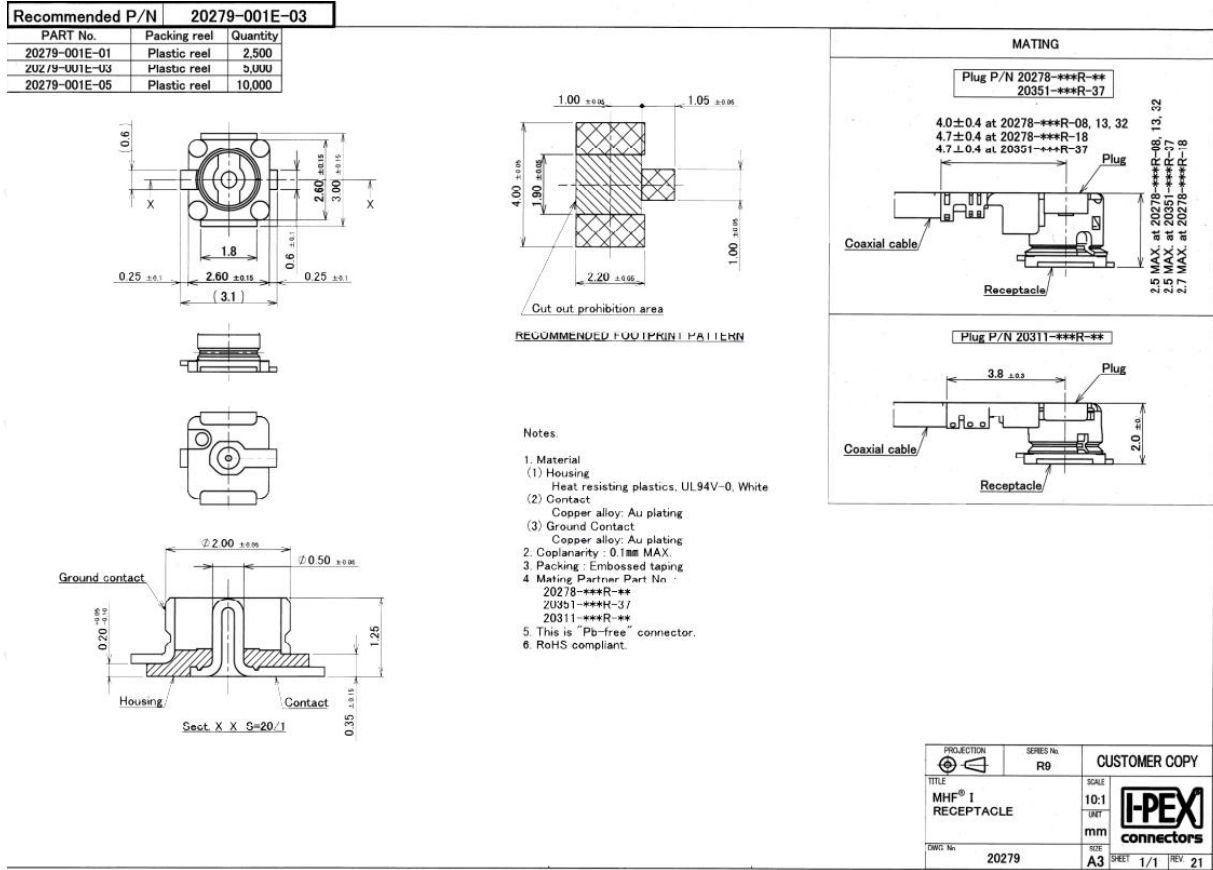

Figure 3: Dimensions of the RF connector

4. Electrical and RF performance of the interface

4.1. Power characteristics

The E106-470G27P2 module is powered by 3.3V, the input voltage is $3.3V \pm 9\%$, and the power input must meet the current supply capacity of at least 500mA. The module input current requirements are shown in the following table:

Table 7: Power input range

Item	Description	Min. Value	Typical value	Max. Value	Unit
VCC	Power supply voltage	3.0	3.3	3.6	V

4.2. IO interface characteristics

The digital IO electrical characteristics of E106-470G27P2 module are shown in the table below.

Table 8: IO interface electrical characteristics

Item	Description	Min. Value	Max. Value	Unit
VIH	Input high voltage	$0.7 * VCC$	$VCC + 0.3$	V
VIL	Input low voltage	-0.3	$0.3 * VCC$	V
VOH	Output high voltage	$VCC - 0.5$	VCC	V
VOL	Output low voltage	0	0.4	V

4.3. Working current

Table 9: Working current

Item	Working condition	Working condition	Unit
RX	Turn on RX, disable TX	54	mA
TX/RX	Turn on Rx, turn on TX@25dBm	360	mA
IDLE	Idle mode	27	mA

4.4. RF performance

Table 10: RF module transmit power

Working frequency	Maximum power value	Unit
505.5MHz	26	dBm
868.5MHz	TBD	dBm
915.5MHz	TBD	dBm

Table 11: RF receiving sensitivity

Working frequency	Spreading factor (BW=125KHZ)	Receiving sensitivity (typical value dBm)
475.5MHz	SF=5	-121
	SF=7	-127
	SF=12	-141
868.5MHz	SF=5	TBD
	SF=7	TBD
	SF=12	TBD
915.5MHz	SF=05	TBD
	SF=07	TBD
	SF=12	TBD

5. Dimensions

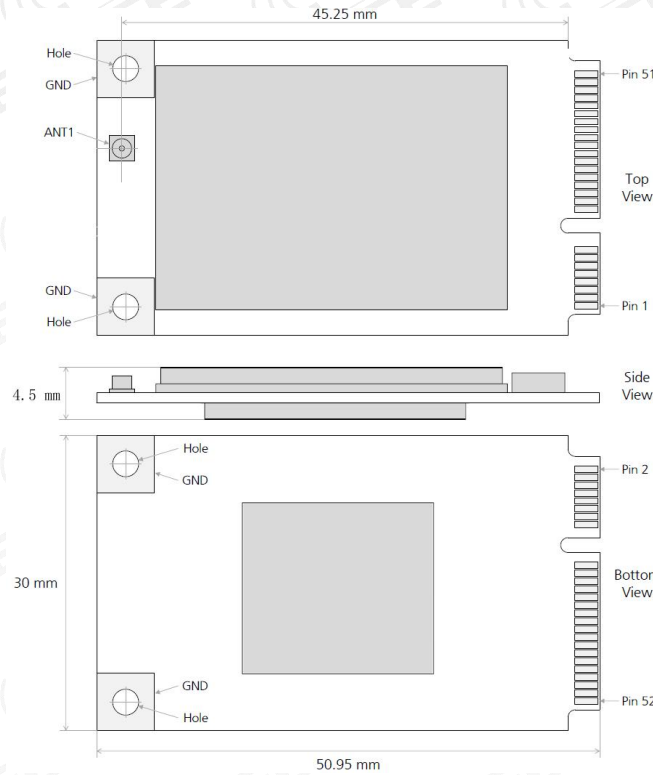

Figure 4: Dimensions of E106-470G27P2 module

PCI Express mini card connectors that meet the standard can be used with this module, as shown in the following figure, MOLEX's 679100002 connector.

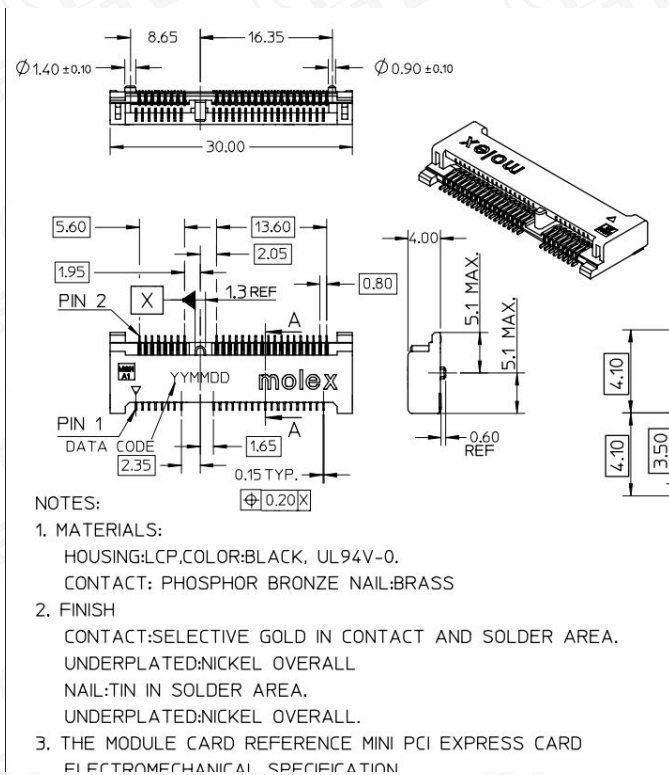

Figure 5: Mini PCI Express connector

6. Internal connection

The following figure is the internal connection diagram of E106-470G27P2 for reference.

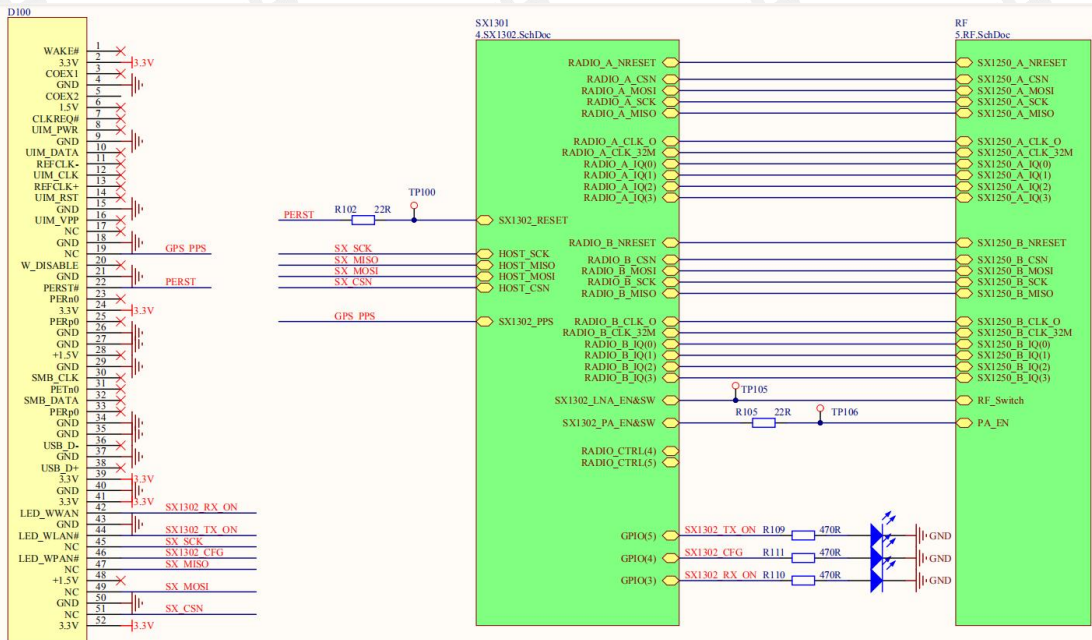

Figure 6: E106-470G27P2 internal connection

7. Reference design

E106-470G27P2 uses SPI interface to connect with the main control chip, and uses DC-DC to supply power to the module, and users can modify it as needed.

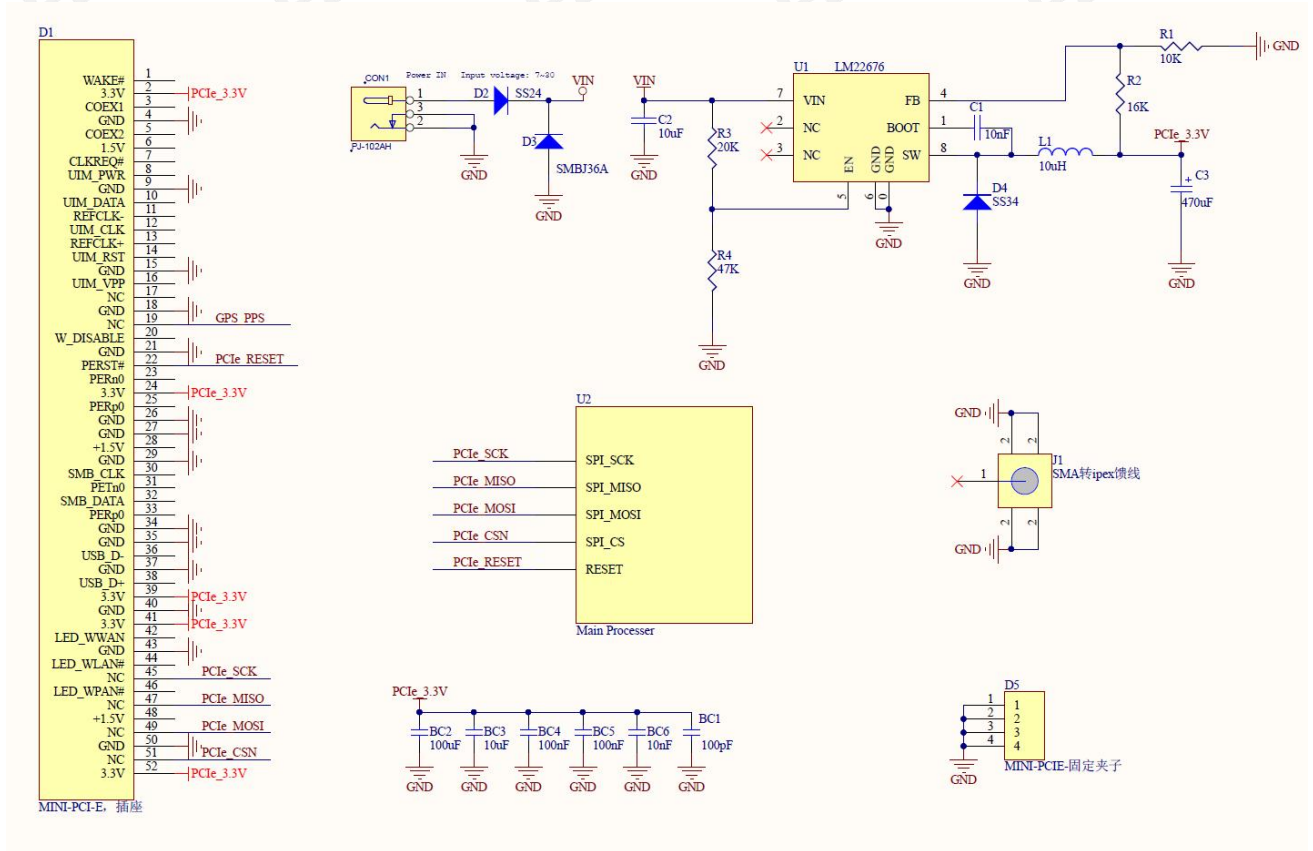

Figure 7: E106-470G27P2 module reference design

About us

Technical support: support@cdebyte.com

Documents and RF Setting download link:: <https://www.cdebyte.com>

Thank you for using Ebyte products! Please contact us with any questions or suggestions: info@cdebyte.com

Web: <https://www.cdebyte.com>

Address: B5 Mould Park, 199# Xiqu Ave, High-tech District, Sichuan, China



Chengdu Ebyte Electronic Technology Co.,Ltd.