



E22-400TXXX Data Sheet

SX1268 433/470MHz LoRa Wireless Module



DISCLAIMER AND COPYRIGHT NOTICE	4
CHAPTER 1 OVERVIEW	0
1.1 INTRODUCTION	0
1.2 FEATURES	1
1.3 APPLICATION	1
CHAPTER 2 SPECIFICATION AND PARAMETER	2
2.1 LIMIT PARAMETERS	2
2.2 OPERATING PARAMETERS	3
2.3 HARDWARE PARAMETERS	4
CHAPTER 3 SIZE AND PIN DEFINITION	5
3.1 E22-400T22S PIN DEFINITION	5
3.2 E22-400T30/33S PIN DEFINITION	6
3.3 E22-400T22D PIN DEFINITION	8
3.4 E22-400T30D PIN DEFINITION	9
3.5 E22-400T33D PIN DEFINITION	11
CHAPTER 4 RECOMMENDED CONNECTION DIAGRAM	13
4.1 E22-400TXXS	13
4.2 E22-400TXXD	13
CHAPTER 5 FUNCTION DESCRIPTION	14
5.1 FIXED TRANSMISSION	14
5.2 BROADCASTING TRANSMISSION	14
5.3 BROADCASTING ADDRESS	14
5.4 LISTENING ADDRESS	15
5.5 MODULE RESET	15
5.6 AUX DESCRIPTION	15
5.6.1 <i>Indication of UART Output</i>	15
5.6.2 <i>Indication of Wireless Transmitting</i>	16
5.6.3 <i>The module is being configured</i>	16
5.6.4 <i>Notes for AUX</i>	16
CHAPTER 6 WORKING MODE	17
6.1 MODE SWITCHING	17
6.2 NORMAL MODE (MODE 0)	18
6.3 WOR MODE (MODE 1)	18

6.4 CONFIGURATION MODE (MODE 2)	18
6.5 DEEP SLEEP MODE (MODE 3)	18
CHAPTER 7 REGISTER READ AND WRITE CONTROL	19
7.1 COMMAND FORMAT	19
7.2 REGISTER DESCRIPTION	20
7.3 FACTORY DEFAULT PARAMETER	22
CHAPTER 8 REPEATER NETWORKING MODE	23
CHAPTER 9 CONFIGURATION INSTRUCTIONS ON COMPUTER	24
CHAPTER 10 HARDWARE DESIGN	25
CHAPTER 11 FAQ	26
11.1 COMMUNICATION RANGE IS TOO SHORT	26
11.2 MODULE IS EASY TO DAMAGE	26
11.3 BER(BIT ERROR RATE) IS HIGH	26
CHAPTER 12 WELDING WORK INSTRUCTIONS	27
12.1 REFLOW SOLDERING TEMPERATURE	27
12.2 REFLOW SOLDERING CURV	27
CHAPTER 13 E22 SERIES	28
CHAPTER 14 ANTENNA RECOMMENDATION	28
14.1 ANTENNA RECOMMENDATION	28
REVISION HISTORY	29
ABOUT US	29

Disclaimer and Copyright Notice

The information in this document, including the URL address for reference, is subject to change without notice. The document is provided "as is" without any guarantee responsibility, including any guarantee for marketability, suitability for a specific purpose, or non-infringement, and any guarantee for any proposal, specification or sample mentioned elsewhere. This document does not bear any responsibility, including the responsibility for infringement of any patent rights caused by the use of the information in this document. This document does not grant any license for the use of intellectual property rights in estoppel or other ways, whether express or implied.

The test data obtained in the article are all obtained by the Ebyte laboratory, and the actual results may vary slightly.

We hereby declared that all brand names, trademarks and registered trademarks mentioned in this document are the property of their respective owners.

The final interpretation right belongs to Chengdu Ebyte Electronic Technology Co., Ltd.

Notice :

Due to product version upgrades or other reasons, the contents of this manual may be changed. Ebyte Electronic Technology Co., Ltd. reserves the right to modify the contents of this manual without any hint or notice. This manual is only used as a guide. Chengdu Ebyte Electronic Technology Co., Ltd. makes every effort to provide accurate information in this manual. However, we does not guarantee that the contents of the manual are completely free of errors. All statements, information and suggestions in this manual do not constitute any express or implied guarantee

Chapter 1 Overview

1.1 Introduction

E22-400TXXX series is a new generation of LoRa wireless module. It is a wireless serial port module (UART) based on SX1268 RF chip, with a variety of transmission methods, working in (410.125 ~ 493.125MHz) frequency band (default 433.125MHz), LoRa spread spectrum technology, with TTL level output, support 2.3V - 5.5V supply voltage.

E22-400TXXX adopts a new generation of LoRa spread spectrum technology. Compared with the traditional SX1278 solution, SX1268 has farther range, faster transmission speed, but with lower power consumption and smaller size;

It supports wake-up over the air, wireless configuration, LBT, automatic relay, communication key and other functions. It also supports packet length setting, and customized development service is available.



1.2 Features

- Based on chip SX1268, the new LoRa spread spectrum modulation technology brings a longer communication distance and stronger anti-interference ability;
- Support automatic relay networking, multi-level relay is suitable for ultra-long-distance communication, and multiple networks can run simultaneously in the same area;
- User can set the communication key by himself and the key cannot be read by others. It greatly improving the confidentiality of user data;
- Support LBT function, monitoring the channel environment noise before sending data, which greatly improves the communication success rate of the module in harsh environments;
- Support RSSI signal strength indicator function for evaluating signal quality, improving communication network, and ranging;
- Support wireless parameter configuration, send command packets wirelessly, remotely configure or read wireless module parameters;
- Support wake-up over the air, that is ultra-low power consumption, suitable for battery-powered applications;
- Support point to point transmission, broadcast transmission, channel listening;
- Support deep sleep, the power consumption of the whole module is about 2uA in this mode;
- Support global license-free ISM 433MHz frequency band, support 470MHz meter reading frequency band;
- The module has built-in PA+LNA, and the communication distance can reach 16km under ideal conditions;
- The parameters are saved after power-off, and the module will work according to the set parameters after power-on;
- Efficient watchdog design, once an exception occurs, the module will automatically restart and continue to work according to the previous parameter settings;
- Support 2.4k~62.5kbps air data rate transmission;
- Support 2.3~5.5V power supply, power supply greater than 3.3V guarantees the best performance;
- Industrial standard design, supporting long-term use at -40~+85°C;
- The maximum power of the module can reach 2W (33dBm), which makes the transmission farther and more stable.

1.3 Application

- Home security alarm and remote keyless entry;
- Smart home and industrial sensors;
- Wireless alarm security system;
- Building automation solutions;
- Wireless industrial-grade remote control;
- Health care products;
- Advanced Meter Reading Architecture (AMI);
- Automotive industry applications.

Chapter 2 Specification and Parameter

2.1 Limit Parameters

RF parm	Unit	Model No.			Remark
		E22-400T22S	E22-400T30S	E22-400T33S	
Operating frequency	MHz	410.125 - 493.125			Support ISM frequency band
Tx power	dBm	22.0±0.5	30.0±0.5	33.0±0.5	
Blocking Power	dBm	0 ~ 10.0			Less chance of burning when used at close range
Receiving sensitivity	dBm	-147±1.0			Air data rate 2.4kbps
Tested range	Km	5	10	12	Test condition: clear and open area, antenna gain: 5dBi, antenna placement height: 2.5m, air data rate: 2.4kbps
Air data rate	bps	2.4k~62.5k			To control via user's program

RF parm	Unit	Model No.			Remark
		E22-400T22D	E22-400T30D	E22-400T33D	
Operating frequency	MHz	410.125 - 493.125			Support ISM frequency band
Tx power	dBm	22.0±0.5	30.0±0.5	33.0±0.5	
Blocking Power	dBm	0 ~ 10.0			Less chance of burning when used at close range
Receiving sensitivity	dBm	-147±1.0			Air data rate 2.4kbps
Tested range	Km	5	10	16	Test condition: clear and open area, antenna gain: 5dBi, antenna placement height: 2.5m, air data rate: 2.4kbps
Air data rate	bps	2.4k~62.5k			To control via user's program

2.2 Operating Parameters

Electrical parm	Unit	Model No.			Remark
		E22-400T22S	E22-400T30S	E22-400T33S	
Operating voltage	V	2.3~5.5V	3.3~5.5V	3.3~5.5V	High-power module \geq 5V ensures output power
Communication level	V	3.3			For 5V TTL, it may be burning down
TX current	mA	110	610	850~1200	Instant power consumption
RX current	mA	13	14	15	
Sleep current	uA	2			software shutdown
Operating temperature	°C	-40 ~ +85			Industrial grade

Electrical parm	Unit	Model No.			Remark
		E22-400T22D	E22-400T30D	E22-400T33D	
Operating voltage	V	2.3~5.5V	3.3~5.5V	3.3~5.5V	High-power module \geq 5V ensures output power
Communication level	V	3.3			For 5V TTL, it may be burning down
TX current	mA	110	610	850~1200	Instant power consumption
RX current	mA	11	16~17	11~15	
Sleep current	uA	2			software shutdown
Operating temperature	°C	-40 ~ +85			Industrial grade

2.3 Hardware Parameters

Main parm	E22-400T22S	E22-400T30S	E22-400T33S	Remark
Size	16*26 mm	25*40.5mm	25*40.5mm	
Weight	2.4g	5.7g	5.7g	±0.1
TX packet length	240 Byte			Can be configured via command as 32/64/128/240bytes per packet to transmit
Buffer	1000 Byte			
Modulation	LoRa			New generation LoRa modulation technology
Communication interface	UART Serial Port			TTL Level
Package type	SMD type, stamp hole, pitch 1.27/2.54mm			
Interface	1.27mm	2.54mm	2.54mm	
PA+LNA	No	Yes	Yes	Module built in PA+LNA

Main parm	E22-400T22D	E22-400T30D	E22-400T33D	Remark
Size	21*36 mm	24*43mm	37*60mm	
Weight	7.5g	9.2g	25.94g	±0.1
TX packet length	240 Byte			Can be configured via command as 32/64/128/240bytes per packet to transmit
Buffer	1000 Byte			
Modulation	LoRa			New generation LoRa modulation technology
Communication interface	UART Serial Port			TTL Level
Package type	DIP			
Interface	2.54mm	2.54mm	2.54mm	
PA+LNA	No	Yes	Yes	Module built in PA+LNA

Chapter 3 Size and Pin Definition

3.1 E22-400T22S Pin definition

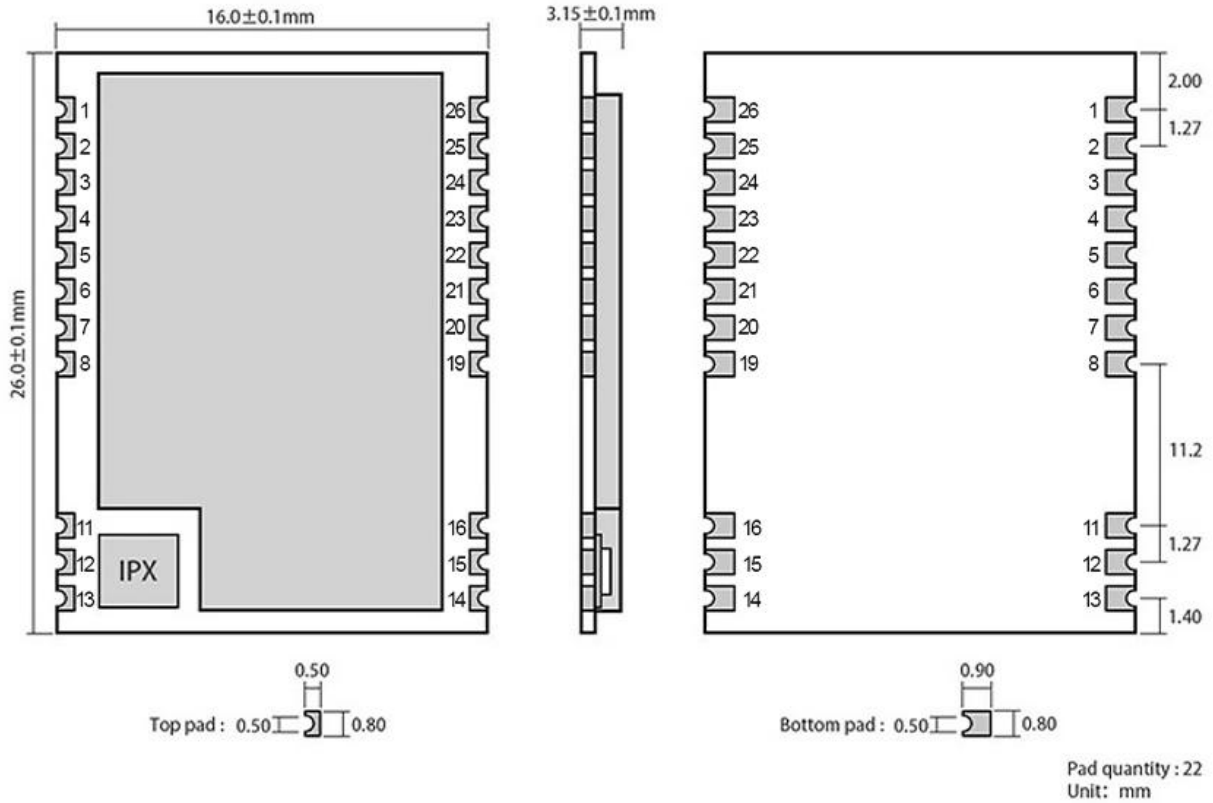

Pin No.	Pin Name	Pin Direction	Pin Function
1	NRST	Input	Module reset pin, low level for reset
2	GND	-	Module ground
3	NC	-	NC
4	NC	-	NC
5	NC	-	NC
6	NC	-	NC
7	NC	-	NC
8	GND	-	Module ground
11	GND	-	Module ground
12	ANT	-	Antenna
13	GND	-	Module ground
14	GND	-	Module ground
15	GND	-	Module ground

16	GND	-	Module ground
19	GND	-	Module ground
20	M0	Input (weak pull-up)	Work with M1 to decide 4 working modes of module (not float, if not used, could be grounded).
21	M1	Input (weak pull-up)	Work with M0 to decide 4 working modes of module (not float, if not used, could be grounded).
22	RXD	Input	TTL UART inputs, connects to external TXD output pin.
23	TXD	Output	TTL UART outputs, connects to external RXD input pin.
24	AUX	Output	Used to indicate the working status of the module;
			For user to wakes up the external MCU and it outputs low level during power-on self-check initialization; (can be left floating)
25	VCC	-	Module power positive reference, voltage range: 2.3 ~ 5.5V DC
26	GND	-	Module ground

3.2 E22-400T30/33S Pin definition

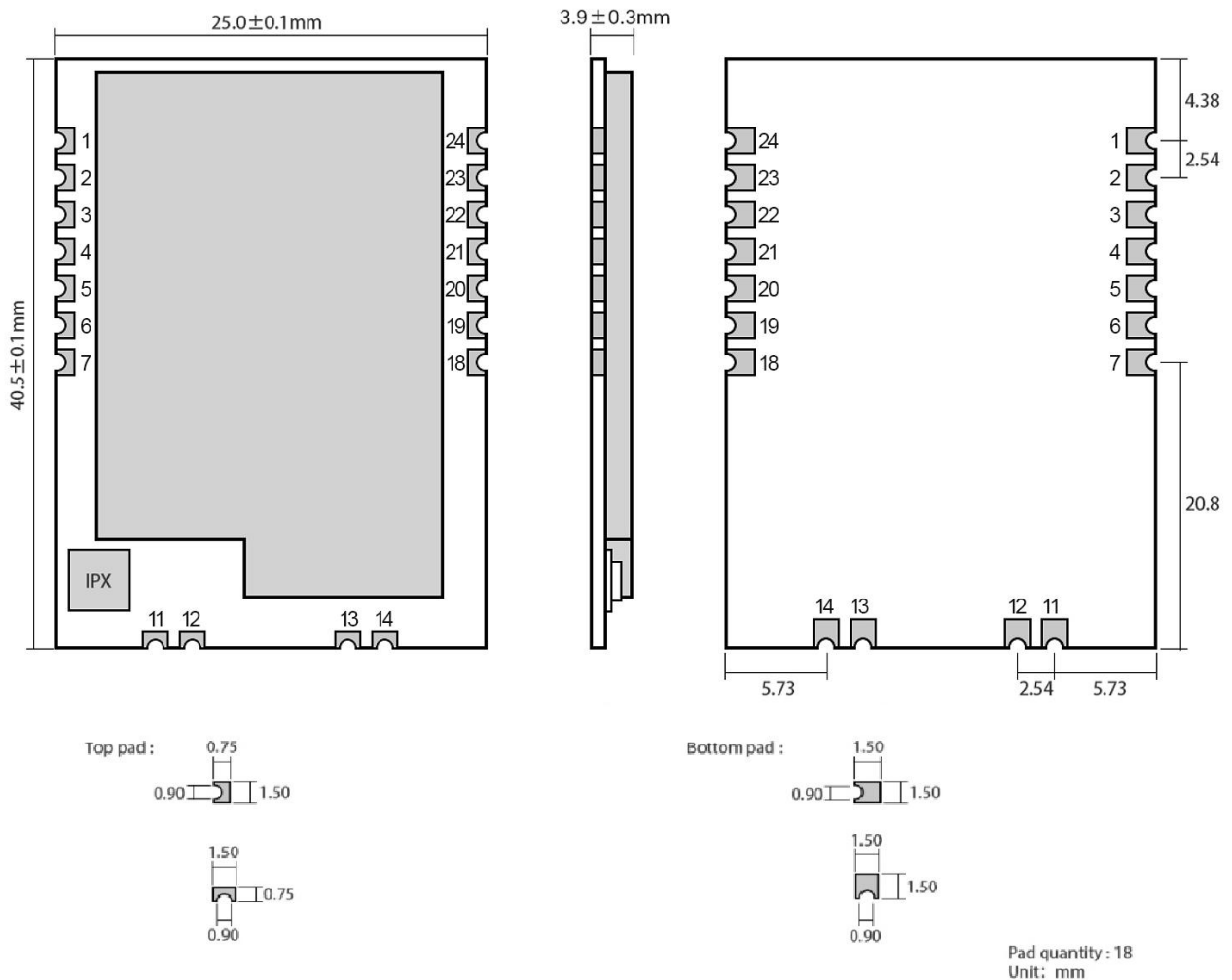

Pin No.	Pin Name	Pin Direction	Pin Function
1	GND	Input	Module ground
2	VCC	Input	Module power positive reference, voltage range:3.3~5.5V DC
3	AUX	Output	Used to indicate the working status of the module;
			For user to wakes up the external MCU and it outputs low level during power-on self-check initialization; (can be left floating)
4	TXD	Output	TTL UART outputs, connects to external RXD input pin.
5	RXD	Input	TTL UART inputs, connects to external TXD output pin.
6	M1	Input (weak pull-up)	Work with M0 to decide 4 working modes of module (not float, if not used, could be grounded).
7	M0	Input (weak pull-up)	Work with M1 to decide 4 working modes of module (not float, if not used, could be grounded).
11	ANT	Output	Antenna interface (High frequency signal output, 50 ohm characteristic impedance)
12	GND	-	Fixed ground
13	GND	-	Fixed ground
14	GND	-	Fixed ground
18	NC	-	NC
19	NC	-	NC
20	NC	-	NC
21	NC	-	NC
22	RESET	Input	RESET pin when the program is loaded (be left floating, the user does not need to connect)
23	GND	Input	Ground pin when loading program (be left floating, the user does not need to connect)
24	NC	-	NC

3.3 E22-400T22D Pin Definition

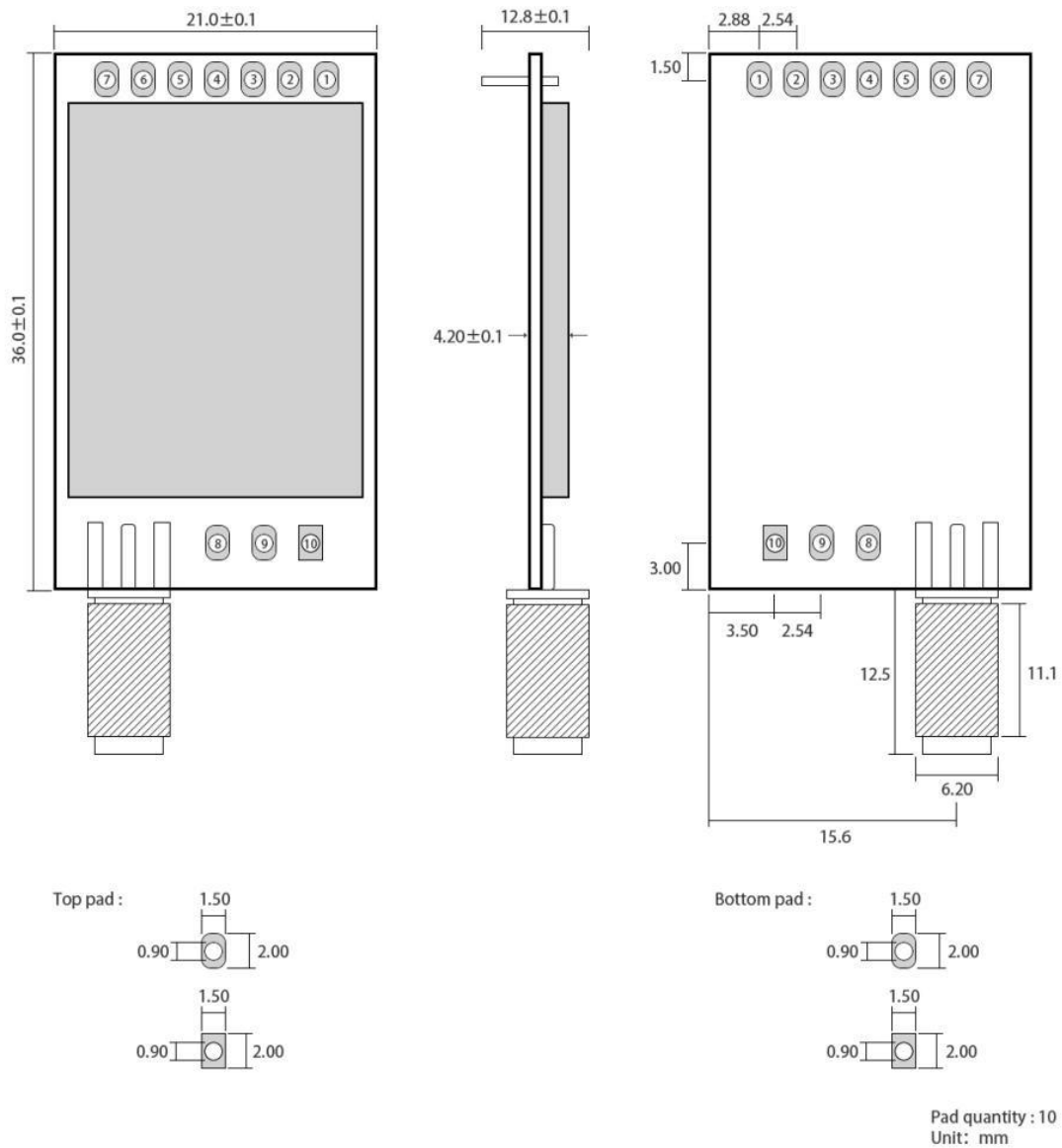

Pin No.	Pin Name	Pin Direction	Pin Function
1	M0	Input (weak pull-up)	Work with M1 to decide 4 working modes of module (not float, if not used, could be grounded).
2	M1	Input (weak pull-up)	Work with M0 to decide 4 working modes of module (not float, if not used, could be grounded).
3	RXD	Input	TTL UART inputs, connects to external TXD output pin.
4	TXD	Output	TTL UART outputs, connects to external RXD input pin.
5	AUX	Output	Used to indicate the working status of the module; For user to wakes up the external MCU and it outputs low level during power-on self-check initialization; (can be left floating)
6	VCC	Input	Module power positive reference, voltage range:2.3~5.5V DC
7	GND	Input	Module ground
8	Fixed hole	-	Fixed hole

9	Fixed hole	-	Fixed hole
10	Fixed hole	-	Fixed hole

3.4 E22-400T30D Pin Definition

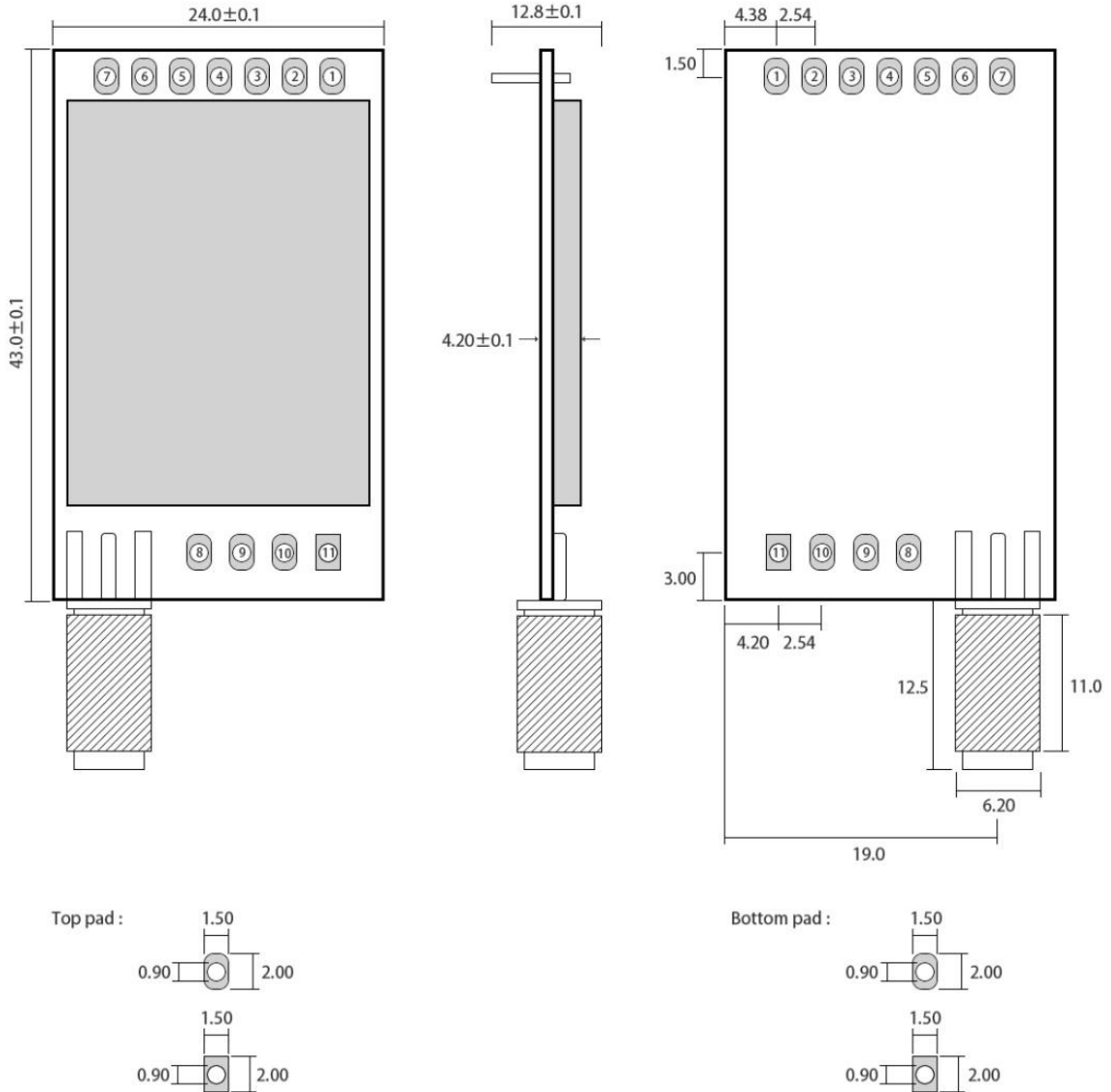

Pad quantity : 11
Unit: mm

Pin No.	Pin Name	Pin Direction	Pin Function
1	M0	Input (weak pull-up)	Work with M1 to decide 4 working modes of module (not float, if not used, could be grounded).
2	M1	Input (weak pull-up)	Work with M0 to decide 4 working modes of module (not float, if not used, could be grounded).
3	RXD	Input	TTL UART inputs, connects to external TXD output pin.

			Can be configured as an open-drain or pull-up input, see parameter settings for details.
4	TXD	Output	TTL UART outputs, connects to external RXD input pin. Can be configured as open-drain or push-pull output, see parameter settings for details.
5	AUX	Output	Used to indicate the working status of the module; For user to wakes up the external MCU and it outputs low level during power-on self-check initialization; It can be configured as open-drain output or push-pull output, see parameter settings for details. (Can be left floating)
6	VCC	Input	Module power positive reference, voltage range:3.3~5.5V DC
7	GND	Input	Module ground
8	Fixed hole	-	Fixed hole
9	Fixed hole	-	Fixed hole
10	Fixed hole	-	Fixed hole
11	Fixed hole	-	Fixed hole

3.5 E22-400T33D Pin Definition

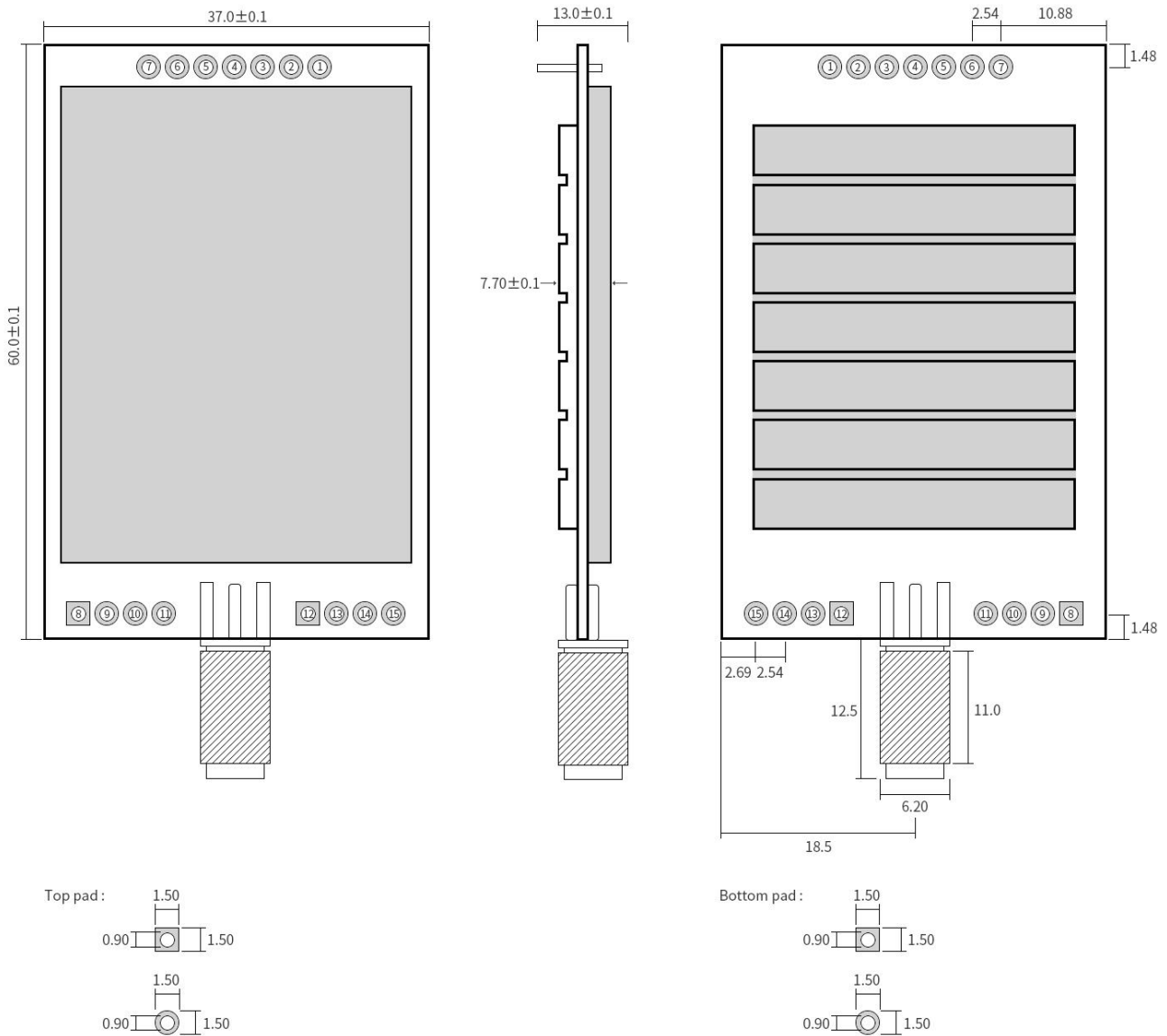

Pad quantity: 15
Unit: mm

Pin No.	Pin Name	Pin Direction	Pin Function
1	M0	Input (weak pull-up)	Work with M1 to decide 4 working modes of module (not float, if not used, could be grounded).
2	M1	Input (weak pull-up)	Work with M0 to decide 4 working modes of module (not float, if not used, could be grounded).
3	RXD	Input	TTL UART inputs, connects to external TXD output pin.
4	TXD	Output	TTL UART outputs, connects to external RXD input pin.

5	AUX	Output	Used to indicate the working status of the module; For user to wakes up the external MCU and it outputs low level during power-on self-check initialization; (Can be left floating)
6	VCC	Input	Connect the reference ground of the module inside
7	GND	Input	Connect the reference ground of the module inside
8	Fixed hole	Input	Connect the reference ground of the module inside
9	Fixed hole	Input	Connect the reference ground of the module inside
10	Fixed hole	Input	Connect the reference ground of the module inside
11	Fixed hole	Input	Connect the reference ground of the module inside
12	Fixed hole	Input	Connect the reference ground of the module inside
13	Fixed hole	Input	Connect the reference ground of the module inside
14	Fixed hole	Input	Connect the reference ground of the module inside
15	Fixed hole	Input	Connect the reference ground of the module inside

Chapter 4 Recommended Connection Diagram

4.1 E22-400TXXS

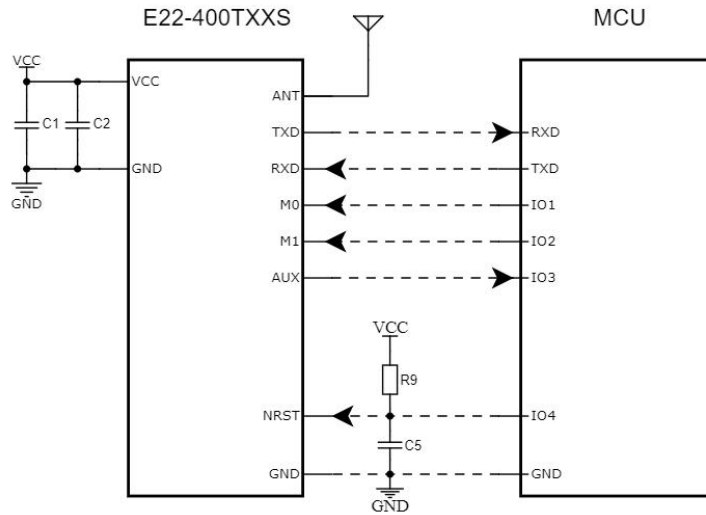

4.2 E22-400TXXD

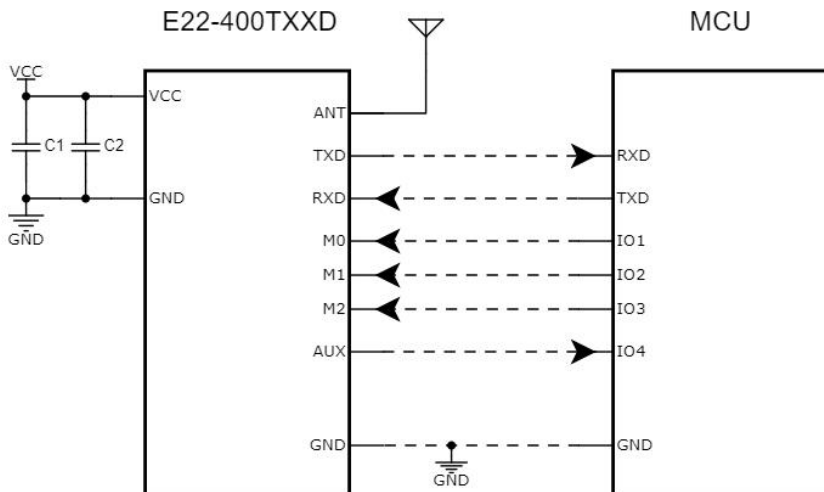

Chapter 5 Function Description

5.1 Fixed Transmission

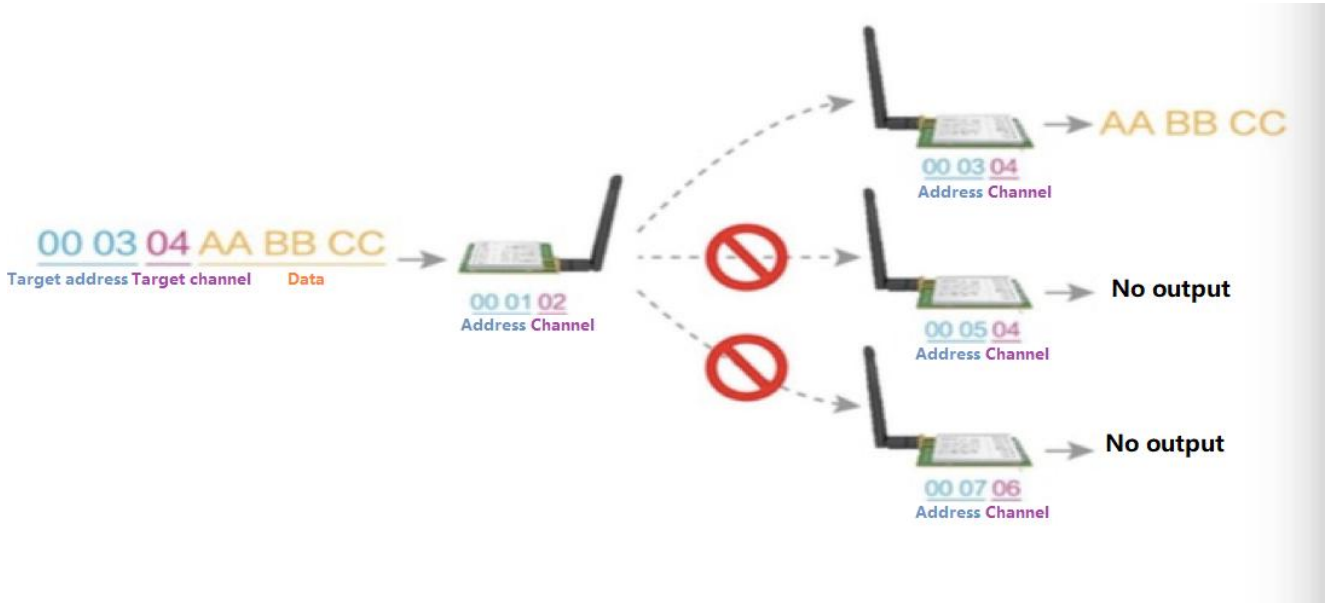

5.2 Broadcasting Transmission

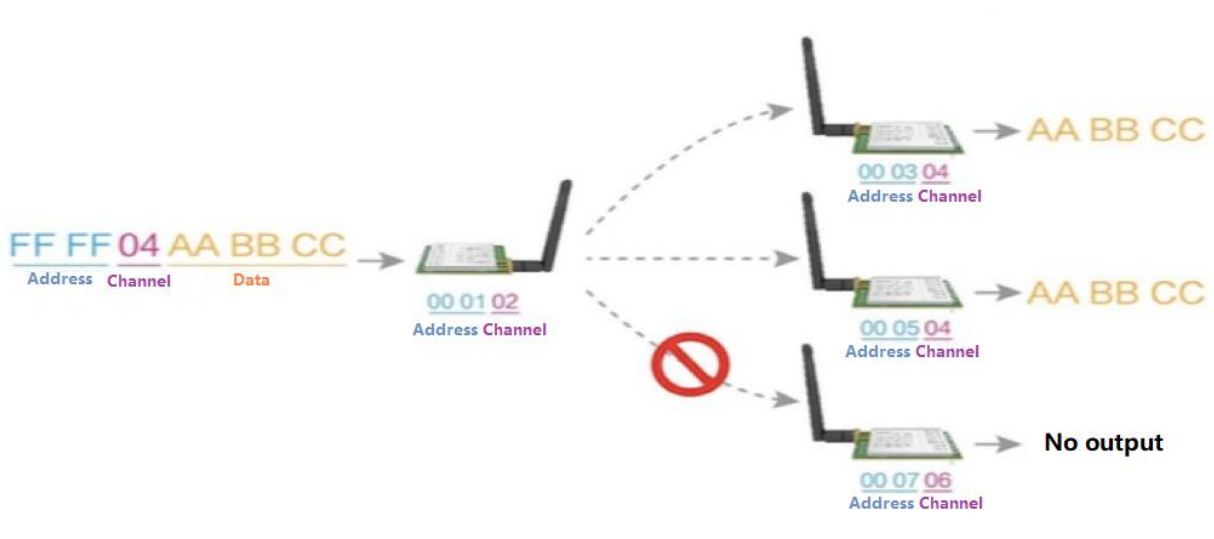

5.3 Broadcasting Address

- For Example: Set the address of module A to 0xFFFF and the channel to 0x04.
- When module A is used as a transmitter (same mode, transparent transmission mode), all receiving modules under the 0x04 channel can receive data to achieve the purpose of broadcasting.

5.4 Listening Address

- For example: Set the address of module A as 0xFFFF, and the channel as 0x04;
- When module A is the receiver, it can receive the data sent from all modules under channel 0x04, the purpose of listening is realized.

5.5 Module Reset

- After the module is powered on, AUX will immediately output low level, perform hardware self-check, and set the working mode according to user parameters;
- During this process, AUX keeps low level, and AUX outputs high level after completion, and starts to work normally according to the working mode formed by M1 and M0; Therefore, the user needs to wait for the rising edge of AUX as the starting point for the module to work normally.

5.6 AUX Description

- AUX Pin can be used as indication for wireless TX &RX buffer and self-check.
- It can indicate whether there is data not transmitted via wireless way, or whether the received data has not been sent through UART, or whether the module is still in the process of self-check initialization.

5.6.1 Indication of UART Output

- To wake up external MCU;

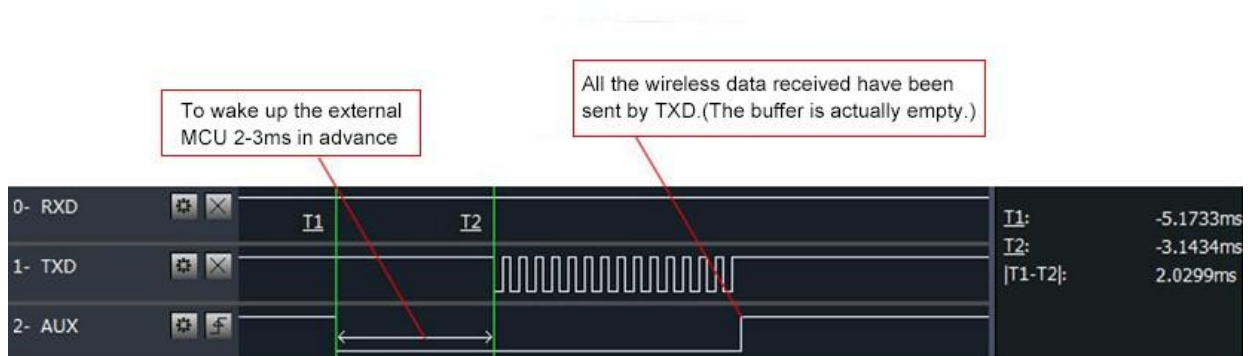

Timing Sequence Diagram of AUX when TXD pin transmits

5.6.2 Indication of Wireless Transmitting

- Buffer empty: the data in the 1000-byte buffer in the module is written to the wireless chip (automatically sub-packaging); When AUX=1, if user continuously sends data less than 1000 bytes, it won't overflow; When AUX=0, the buffer is not empty: It means data in the module's internal 1000-byte buffer has not been written to the wireless chip and has not been transmitted. At this time, the module may be waiting for the end of user input data (subject to timeout), or the module is going on with wireless sub-packet transmission.
[Note]: When AUX=1, it does not mean that all serial port data of the module has been transmitted through wireless; It may be in the case that the last data packet is being transmitted.

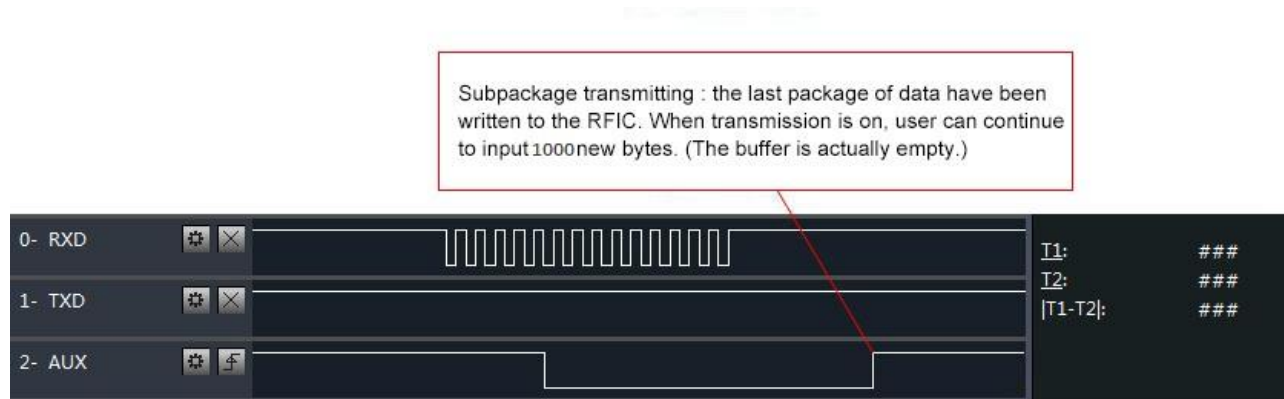

Timing Sequence Diagram of AUX when RXD pin receives

5.6.3 The module is being configured

- Only happened when resetting or exiting sleep mode

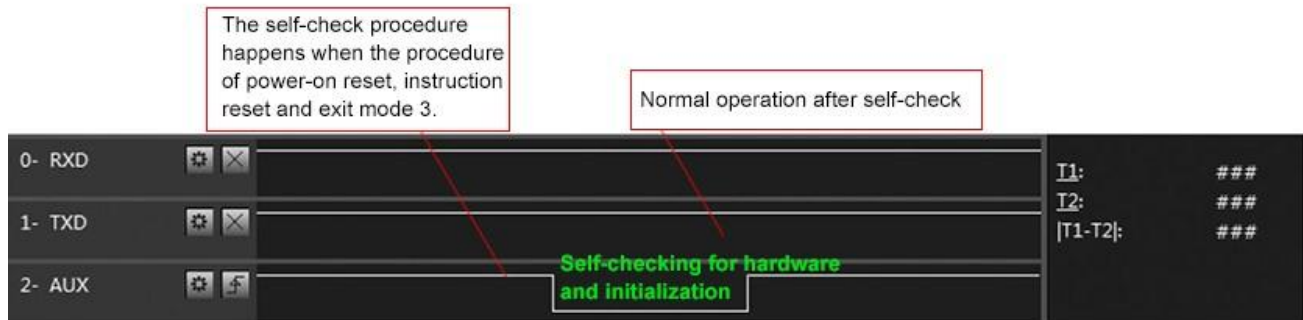

Timing Sequence Diagram of AUX when self-check

5.6.4 Notes for AUX

No.	Notes for AUX
1	For function 1 (5.6.1) & function 2 (5.6.2) mentioned above, the priority should be given to the one with low level output, which means as long as any output low level condition is met, AUX will output low level; Only when none of the output low level condition is met, AUX will outputs high level.
2	When AUX outputs low level, it means the module is busy & it won't conduct working mode checking. Within 1ms since AUX outputs high level, the module working mode switch will be completed.
3	After switching to new working mode, module will not work in the new mode immediately until AUX rising edge lasts for 2ms. If AUX is always at high level, then the mode switch will take effect immediately;

4	When the user switches to other working modes from mode 3 (sleep mode) or it is still in reset process, the module will reset user parameters, during which AUX outputs low level.
5	Due to the characteristics of the LoRa modulation method, the information transmission delay is much longer than FSK. To avoid communication abnormalities caused by data accumulation and data loss, customer is suggested not to transmit large amounts of data at low air data rate.

Chapter 6 Working Mode

There are four working modes, which are set by M1 and M0, the details are as follows:

Mode (0-3)	M1	M0	Description	Remark
0 Transmission Mode	0	0	UART and wireless channel are open, transparent transmission is on	Support over-the-air configuration via special command
1 WOR Mode	0	1	Can be set as WOR Transmitter or WOR Receiver	Support wake up over the air
2 Configuration Mode	1	0	Users can access the registers through the serial port to control the working status of the module	
3 Deep Sleep Mode	1	1	Module goes to sleep	

6.1 Mode Switching

No.	Remark
1	<ul style="list-style-type: none"> Users can combine high and low levels with M1 and M0 to determine the module's working mode. Two GPIOs of the MCU can be used to control mode switching; After changing M1 and M0: If the module is idle, after 1ms, it can start working according to the new mode; If there is serial port data of the module not been transmitted through the wireless, the new working mode can be switched after the transmission is completed; If the module receives the wireless data and transmits the data through the serial port, it needs to finish transmission before switching to the new working mode; Therefore, mode switching can only be valid when AUX output is 1, otherwise it will delay switching
2	<ul style="list-style-type: none"> For example, users continuously inputs a large amount of data and simultaneously performs mode switching. At this time, the switching mode operation is invalid; the module will process all the user data before performing the new mode detection; Therefore, the general recommendation is to detect the output state of the AUX pin and switch mode after 2ms when AUX outputs high level.
3	<ul style="list-style-type: none"> When the module is switched to sleep mode from other modes, if there is data not been processed yet, the module will process these data (including receiving and sending) before entering sleep mode. This feature can be used for fast sleep to save power; For example, the transmitter module works in mode 0, the user transmits the serial port data "12345". At the time, user does need to wait for the AUX pin to be idle (high level), user can directly switch the module to sleep mode and make user's main MCU immediately sleep, then the module will automatically transmit the user data through the wireless, and will enters sleep mode within 1ms automatically; This will saves MCU's working time and reduces its power consumption.
4	<ul style="list-style-type: none"> Similarly, any mode switching can use this feature. After the module processes the event in the current mode, it will automatically enter the new mode within 1ms; This saves the user's work of querying AUX and it achieves the purpose of fast switching; For example, switching from the transmit mode to the receive mode; the user MCU can also enter sleep before the mode switch, and use the external interrupt function to acquire the AUX change, thereby performing mode switching.

5	<ul style="list-style-type: none"> This operation mode is very flexible and efficient. It is designed according to the user's MCU's operation convenience, and it can reduce the workload of the entire system as much as possible, improving system efficiency, and reducing power consumption as well..
---	--

6.2 Normal mode (Mode 0)

Type	When M0 = 0, M1 = 0, module works in Mode 0
Transmitting	Users can input data through the serial port and the module will start wireless transmission.
Receiving	The module wireless receiving function is turned on, and after receiving the wireless data, it will be output through the serial port TXD pin.

6.3 WOR mode (Mode 1)

Type	When M0 = 1, M1 = 0, module works in Mode 1
Transmitting	When defined as the transmitter, the wake-up code for a certain period of time will be automatically added before transmitting
Receiving	Data can be received normally, and the receiving function is equivalent to that in mode 0

6.4 Configuration mode (Mode 2)

Type	When M0 = 0, M1 = 1, module works in Mode 2
Transmitting	Wireless transmitting off
Receiving	Wireless receiving off
Configuration	User can access registers to configure module operating status

6.5 Deep sleep mode (Mode 3)

Type	When M0 = 1, M1 = 1, module works in Mode 3
Transmitting	Unable to transmit wireless data

Receiving	Unable to receive wireless data
Note	When entering other modes from sleep mode, the module will reconfigure parameters. During the configuration process, AUX stays in low level; After completion of configuration, AUX will output a high level, so user is recommended to detect the rising edge of AUX.

Chapter 7 Register read and write control

7.1 Command format

In configuration mode (mode 2: M0 = 0, M1 = 1), the list of supported commands are as follows (only 9600, 8N1 format is supported when setting):

No.	Command format	Description																		
1	Set register	<p>Command: C0+starting address+length+parameters Response: C1+starting address+length+parameters</p> <p>E.g 1: Configure Channel to be 0x09</p> <table border="0"> <tr> <td></td> <td>command</td> <td>starting address</td> <td>length</td> <td>parameter</td> </tr> <tr> <td>Send:</td> <td>C0</td> <td>05</td> <td>01</td> <td>09</td> </tr> <tr> <td>Return:</td> <td>C1</td> <td>05</td> <td>01</td> <td>09</td> </tr> </table> <p>E.g 2: Configure module address (0x1234), network address (0x00), serial port (9600 8N1) and air data rate (2.4K). Send: C0 00 04 12 34 00 61 Return: C1 00 04 12 34 00 61</p>		command	starting address	length	parameter	Send:	C0	05	01	09	Return:	C1	05	01	09			
	command	starting address	length	parameter																
Send:	C0	05	01	09																
Return:	C1	05	01	09																
2	Read register	<p>Command: C1+starting address+ length Response: C1+starting address+length+parameters</p> <p>E.g 1: Read channel</p> <table border="0"> <tr> <td></td> <td>command</td> <td>starting address</td> <td>length</td> <td>parameter</td> </tr> <tr> <td>Send:</td> <td>C1</td> <td>05</td> <td>01</td> <td></td> </tr> <tr> <td>Return:</td> <td>C1</td> <td>05</td> <td>01</td> <td>09</td> </tr> </table> <p>E.g 2: Read module address, network address, serial port and air data rate. Send: C1 00 04 Return: C1 00 04 12 34 00 61</p>		command	starting address	length	parameter	Send:	C1	05	01		Return:	C1	05	01	09			
	command	starting address	length	parameter																
Send:	C1	05	01																	
Return:	C1	05	01	09																
3	Set temporary registers	<p>Command: C2+starting address+length+parameters Response: C1+starting address+length+parameters</p> <p>E.g 1: Configure Channel to be 0x09</p> <table border="0"> <tr> <td></td> <td>command</td> <td>starting address</td> <td>length</td> <td>parameter</td> </tr> <tr> <td>Send:</td> <td>C2</td> <td>05</td> <td>01</td> <td>09</td> </tr> <tr> <td>Return:</td> <td>C1</td> <td>05</td> <td>01</td> <td>09</td> </tr> </table> <p>E.g 2: Configure module address (0x1234), network address (0x00), serial port (9600 8N1) and air data rate (2.4K). Send: C2 00 04 12 34 00 61 Return: C1 00 04 12 34 00 61</p>		command	starting address	length	parameter	Send:	C2	05	01	09	Return:	C1	05	01	09			
	command	starting address	length	parameter																
Send:	C2	05	01	09																
Return:	C1	05	01	09																
5	Wireless configuration	<p>Command: CF CF + normal command Respond: CF CF + normal respond</p> <p>E.g 1: Configure Channel to be 0x09 by wireless configuration</p> <table border="0"> <tr> <td></td> <td>Command head</td> <td>command</td> <td>starting address</td> <td>length</td> <td>parameter</td> </tr> <tr> <td>Send:</td> <td>CF CF</td> <td>C0</td> <td>05</td> <td>01</td> <td>09</td> </tr> <tr> <td>Return:</td> <td>CF CF</td> <td>C1</td> <td>05</td> <td>01</td> <td>09</td> </tr> </table>		Command head	command	starting address	length	parameter	Send:	CF CF	C0	05	01	09	Return:	CF CF	C1	05	01	09
	Command head	command	starting address	length	parameter															
Send:	CF CF	C0	05	01	09															
Return:	CF CF	C1	05	01	09															

		E.g 2: Configure module address (0x1234), network address (0x00), serial port (9600 8N1) and air data rate (2.4K) by wireless configuration. Send: CF CF C0 00 04 12 34 00 61 Return: CF CF C1 00 04 12 34 00 61
6	Wrong format	Wrong format respond: FF FF FF

7.2 Register description

No.	Read or write	Name	Description	Remark	
00H	Read/Write	ADDH	ADDH (default 0)	High byte and low byte in the module address; Note: When the module address is FFFF, it can be used as the broadcast and listening address, that is: the module will not perform address filtering.	
01H	Read/Write	ADDL	ADDL (default 0)		
02H	Read/Write	NETID	NETID (default 0)	Network address, used to distinguish the network. When two or more modules need to communicate with each other, their network address should be the same.	
03H	Read/Write	REG0	7 6 5	UART Serial port rate (bps)	For the two modules communicating with each other, their serial port baud rate can be different, and their serial parity bit can also be different. When transmitting large packets continuously, users need to consider the data blocking and possible data loss caused by the same baud rate. It is generally recommended that both communication parties have the same baud rate.
			0 0 0	Serial port baud rate 1200	
			0 0 1	Serial port baud rate 2400	
			0 1 0	Serial port baud rate 4800	
			0 1 1	Serial port baud rate 9600 (default)	
			1 0 0	Serial port baud rate 19200	
			1 0 1	Serial port baud rate 38400	
			1 1 0	Serial port baud rate 57600	
			1 1 1	Serial port baud rate 115200	
			4 3	Serial parity bit	The communication parties can have different serial parity bit.
			0 0	8N1 (default)	
			0 1	8O1	
			1 0	8E1	
			1 1	8N1 (equal to 00)	The communication parties must have the same air data rate. The higher the air data rate is, the smaller the delay in response, and the shorter the transmission distance is.
			2 1 0	Wireless air data rate (bps)	
			0 0 0	Air data rate 2.4K	
0 0 1	Air data rate 2.4K				
0 1 0	Air data rate 2.4k (default)				
0 1 1	Air data rate 4.8k				
1 0 0	Air data rate 9.6k				
1 0 1	Air data rate 19.2k				
1 1 0	Air data rate 38.4k				

			1	1	1	Air data rate 62.5k		
04H	Read/ Write	REG1	7	6	Sub packet setting		When the data sent is smaller than the sub packet length, the serial output of the receiving end is an uninterrupted continuous output. When the data sent is larger than the sub packet length, the serial port in receiving end will sub packet the data and then output them.	
			0	0	240 bytes (default)			
			0	1	128 bytes			
			1	0	64 bytes			
			1	1	32 bytes			
			5	RSSI Ambient noise enable		RSSI enable command (Sub packet setting, transmit power as default parameters, configuration mode): C0 04 01 20;		
			0	Disable (default)				
			1	Enable		After enabling, the command C0 C1 C2 C3 can be sent in the normal mode(mode 0) or WOR transmission mode (transmitter in mode 1) to read the register; Register 0x00: current ambient noise RSSI; Register 0X01: RSSI at Last Data Received (Current channel noise is: dBm = -(256 - RSSI)); Command format: C0 C1 C2 C3+start address+read length; Return: C1 + address + read length + read valid value; For example: Send: C0 C1 C2 C3 00 01 Return: C1 00 01 RSSI (the address can only start from 00)		
			4	3	2	Reserve		
			1	0	Transmitting power		Power and current are nonlinear, and power efficiency is highest at maximum power. The current does not decrease in proportion to the decrease in power.	
			0	0	22/30/33dBm (default)			
			0	1	17/27/30dBm			
			1	0	14/24/27dBm			
			1	1	11/21/24dBm			
05H	Read/ Write	REG2	Channel control (CH) 0-83 represents a total of 84 channels				Actual Frequency= 410.125 + CH *1M	
06H	Read/ Write	REG3	7	Enable RSSI		After enabled, when the module receives the wireless data, it will follow an RSSI strength byte after output via the serial port TXD		
			0	Disable (default)				
			1	Enable				
			6	Transmission mode		In Fixed point transmission mode, the module recognizes the first three bytes of the serial data as: address high + address low + channel and takes it as the wireless transmitting target.		
			0	Transparent transmission mode (default)				
			1	Fixed point transmission mode				
			5	Repeater function		After the repeater function is enabled, if the target address is not the module itself, the module will forward it once.		
			0	Disable repeater function (default)				
1	Enable repeater function		In order to prevent data return-back, it is recommended to use it in conjunction with the fixed-point transmission mode. That is: the target address is different from the source address.					

			4	LBT enable			<p>When LBT is enabled, it will listen before gtransmitting the wireless data. This can avoid interference to a certain extent, but it may cause data delay.</p> <p>The maximum stay time of LBT is 2 seconds. The wireless data will be transmitted forcibly after 2 seconds.</p>	
			0	Disable (default)				
			1	Enable				
			3	WOR transceiver control			Below operation is valid for Mode 1 only;	
			0	<p>WOR receiver (default)</p> <p>Working in WOR listening mode, the listening period is shown below (WOR period), which can save a lot of power consumption.</p>			<p>In WOR receiving mode (as WOR receiver), the delay time after wake-up can be modified. The default time is 0;</p> <p>1. To modify the delay time after wake-up, WOR receiver needs to send the command C0 09 02 03 E8 in the configuration mode (C0 is writing command, 09 is the starting address of the register, 02 is the length, 03 E8 is the set delay, the maximum delay FFFF is 65535ms, if the delay is set to 0, the wake-up delay is turn off.)</p> <p>2. Data can be sent within the delay.</p>	
			1	<p>WOR transmitter</p> <p>The module receiving and transmitting functions are turned on, and a wake-up code of a period of time is added when transmitting data.</p>				
			2	1	0	WOR cycle time		<p>Below description is valid for Mode 1 only;</p> <p>Cycle time $T = (1 + WOR) * 500ms$, max.4000ms, min.500ms;</p> <p>The longer the cycle time T (WOR listening interval period), the lower the average power consumption, but the greater the data delay.</p> <p>Both the transmitter and the receiver must be set as the same cycle time T (very important).</p>
			0	0	0	500ms		
			0	0	1	1000ms		
			0	1	0	1500ms		
			0	1	1	2000ms		
			1	0	0	2500ms		
			1	0	1	3000ms		
1	1	0	3500ms					
1	1	1	4000ms					
07H	Write	CRYPT_H	High byte of Key (default 0)			Write only, read returns 0		
08H	Write	CRYPT_L	Low byte of Key (default 0)			Used for user encryption to avoid interception of wireless data over the air by similar modules. The module will internally use these two bytes as a calculation factor to do a transform encryption processing for the wireless signal over the air..		
80H~86H	Read	PID	Product information: 7bytes			Product information: 7bytes		

7.3 Factory default parameter

Item	Factory default parameter: C0 00 00 62 00 17						
Model No	Frequency	Address	Channel	Air data rate	Baud rate	Parity format	Power
E22-400TXXS/D	433.125MHz	0x0000	0x17	2.4kbps	9600	8N1	22/30/33dBm

Chapter 8 Repeater networking mode

No.	Repeater mode description
1	User need to set the repeater function in configuration mode. After setting, switch module to the normal mode. Then the repeater starts working.
2	In the repeater mode, ADDH/ADDL is no longer used as the module address, it is used as a NETID to pair and forwarding. If the repeater receive the data from a network, then it will forward the data to the other network. The network ID of the repeater itself is invalid in this case. (See below examples)
3	The repeater module cannot transmit and receive data, and cannot perform low-power operation.
4	When module enters the other modes from mode 3 (sleep mode) or during the reset process, it will reset the user parameters. During this period, AUX outputs low level.

Repeater networking rules:

1. Forwarding rules: the repeater can forward data in both directions between two NETIDs.
2. In repeater mode, ADDH\ADDL is no longer used as the module address. It is used as a NETID to pair and forwarding.

As shown in the figure:

① Primary repeater

“Node 1” NETID is 08.

“Node 2” NETID is 33.

ADDH\ADDL of Repeater 1 are 08, 33 respectively.

So the data sent by node 1 (08) can be forwarded to node 2 (33)

Meanwhile,node 1 and node 2 have the same address, so the data transmitted by node 1 can be received by node 2.

② Secondary repeater

ADDH\ADDL of Repeater 2 are 33, 05 respectively.

Therefore, Repeater 2 can forward the data of Repeater 1 to the network NETID: 05.

Thus node 3 and node 4 can receive the data from node . Node 4 outputs data normally, but no ourput from Node3 because Node 3 has a differer address from Node 1.

③ Two-way repeater

As shown in below: The data sent by Node 1 can be received by Node 2 and Node 4; The data sent by by Node 2 and Node 4 can also be received by Node 1.

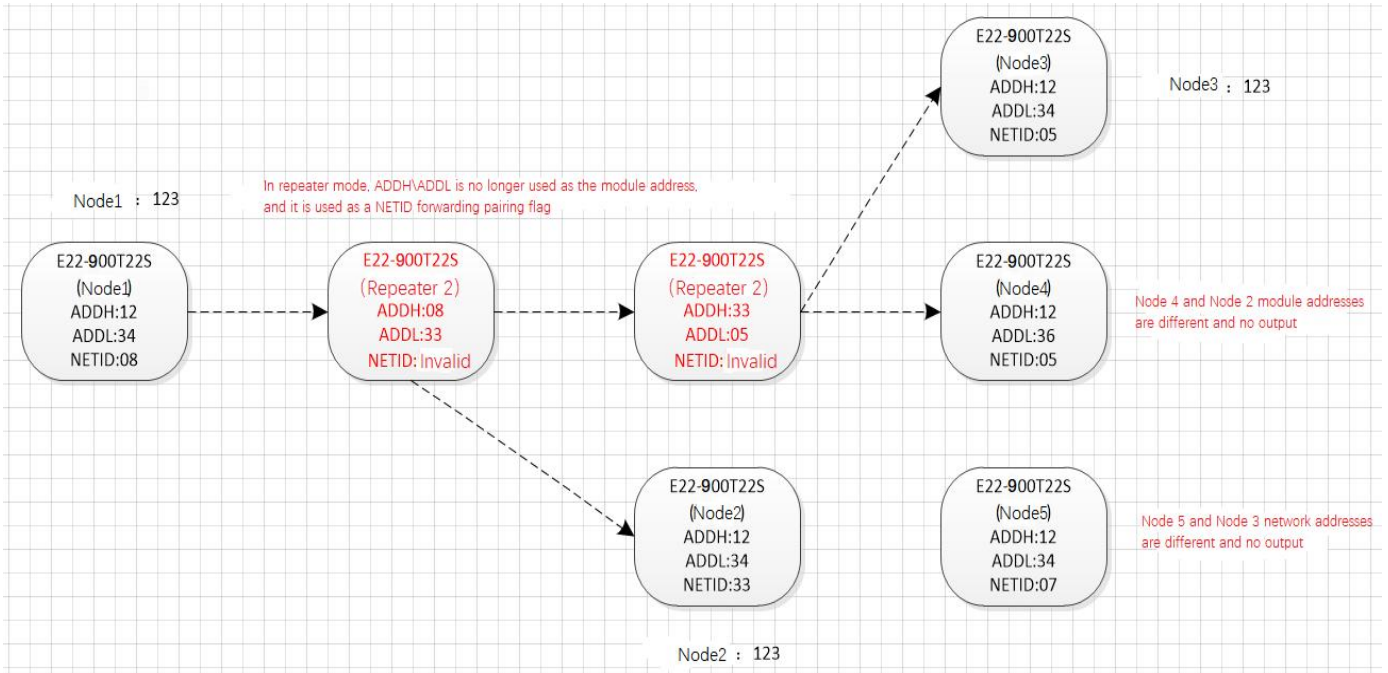

Chapter 9 Configuration instructions on computer

- The following figure is the display interface of E22-400T33D configuration on computer. User can switch to the command mode through M0, M1, and quickly configure and read the parameters on computer.



- In the configuration on computer, the module address, Channel, network ID, and key are all in decimal. The range of values of each parameter is:

Network address: 0~65535

Channel: 0~83

Network ID: 0~255

Key: 0~65535

- When user configures the repeater mode using the host computer, one point much be paid attention to: In the configuration software, each parameter is in decimal, so the module address and network ID need to be converted when set it.
- For example, in the configure software, if the network ID of Transmitter A is input 02, and the network ID of Receiver B is input 10, then the module address of Repeater R should be set as 522. (The address of Repeater R is 0X020A in hex, and it need to be converted to decimal.)

Chapter 10 Hardware design

- It is recommended to use a DC stabilized power supply. The power supply ripple factor is as small as possible, and the module needs to be reliably grounded.;
- Please pay attention to the correct connection of the positive and negative poles of the power supply. Reverse connection may cause permanent damage to the module ; It is recommended to add an anti-reverse connection circuit in the design.
- Please check the power supply to ensure it is within the recommended voltage, otherwise, the module will be permanently damaged when it exceeds the maximum voltage;
- Please check the stability of the power supply, the voltage can not be fluctuated frequently;
- When designing the power supply circuit for the module, it is often recommended to reserve more than 30% of the margin, which is beneficial for long-term stable operation of the whole machine ;
- The module should be as far away as possible from the power supply, transformers, high-frequency wiring and other parts with large electromagnetic interference.;
- High-frequency digital routing, high-frequency analog routing, and power routing must be avoided under the module. If it is necessary to pass through the module, assume that the module is soldered to the Top Layer, and the copper is spread on the Top Layer of the module contact part(well grounded), it must be close to the digital part of the module and routed in the Bottom Layer;
- Assuming the module is soldered or placed over the Top Layer, it is wrong to randomly route over the Bottom Layer or other layers, which will affect the module's spurs and receiving sensitivity to varying degrees;
- It is assumed that there are devices with large electromagnetic interference around the module that will greatly affect the performance. It is recommended to keep them away from the module according to the strength of the interference. If necessary, appropriate isolation and shielding can be done;
- Assume that there are traces with large electromagnetic interference (high-frequency digital, high-frequency analog, power traces) around the module that will greatly affect the performance of the module. It is recommended to stay away from the module according to the strength of the interference.If necessary, appropriate isolation and shielding can be done.
- If the communication line uses a 5V level, a 1k-5.1k resistor must be connected in series (5V communication level is not recommended, there is still a risk of damage);
- The mounting structure of antenna has a great influence on the performance of the module. It is necessary to ensure that the antenna is exposed, preferably vertically upward.
- When the module is mounted inside the case, user could use a good antenna extension cable to extend the antenna to the outside;
- The antenna must not be installed inside the metal case, which will decrease the transmission distance greatly.

Chapter 11 FAQ

11.1 Communication range is too short

- When there is a straight-line communication obstacle, the communication distance will be attenuated accordingly;
- Temperature, humidity, and co-channel interference will increase the communication packet loss rate;
- The ground will absorb and reflect wireless radio wave, so the performance will be poor when testing module near ground.
- Sea water has great ability in absorbing wireless radio wave, so performance will be poor when testing near the sea.
- The signal will be attenuated seriously when there is metal objects near the antenna or module is put in a metal case.
- Power register was set incorrectly, air data rate is set too high (the higher the air data rate, the shorter the transmission distance).
- The power supply voltage is lower than the recommended value under room temperature. (the lower the voltage, the lower the transmitting power.)
- Due to antenna quality or poor matching between antenna and module.

11.2 Module is easy to damage

- Please check the power supply, ensure it is in right range, voltage higher than max value will damage the module.
- Please check the stability of power supply, the voltage cannot fluctuate too much.
- Please ensure anti-static operation during installation and in use, high-frequency devices are sensitive to static electricity
- Please ensure that the humidity during installation and in use should not be too high, some components are sensitive to humidity.
- Please avoid using modules at too high or too low temperature if there is no special requirement.

11.3 BER(Bit Error Rate) is high

- There are co-channel signal interference nearby, please be away from interference sources or modify frequency and channel to avoid interference;
- Poor power supply may cause messy code. Make sure that the power supply is reliable.
- The extension line and feeder quality are poor or too long, so the bit error rate is high;

Chapter 12 Welding Work Instructions

12.1 Reflow soldering temperature

Profile Feature	Sn-Pb Assembly	Pb-Free Assembly
Solder Paste	Sn63/Pb37	Sn96.5/Ag3/Cu0.5
Preheat Temperature min (T _{smin})	100°C	150°C
Preheat temperature max (T _{smax})	150°C	200°C
Preheat Time (T _{smin} to T _{smax})(ts)	60-120 sec	60-120 sec
Average ramp-up rate(T _{smax} to T _p)	3°C/second max	3°C/second max
Liquidous Temperature (TL)	183°C	217°C
Time (t _L) Maintained Above (TL)	60-90 sec	30-90 sec
Peak temperature (T _p)	220-235°C	230-250°C
Average ramp-down rate (T _p to T _{smax})	6°C/second max	6°C/second max
Time 25°C to peak temperature	6 minutes max	8 minutes max

12.2 Reflow soldering curv

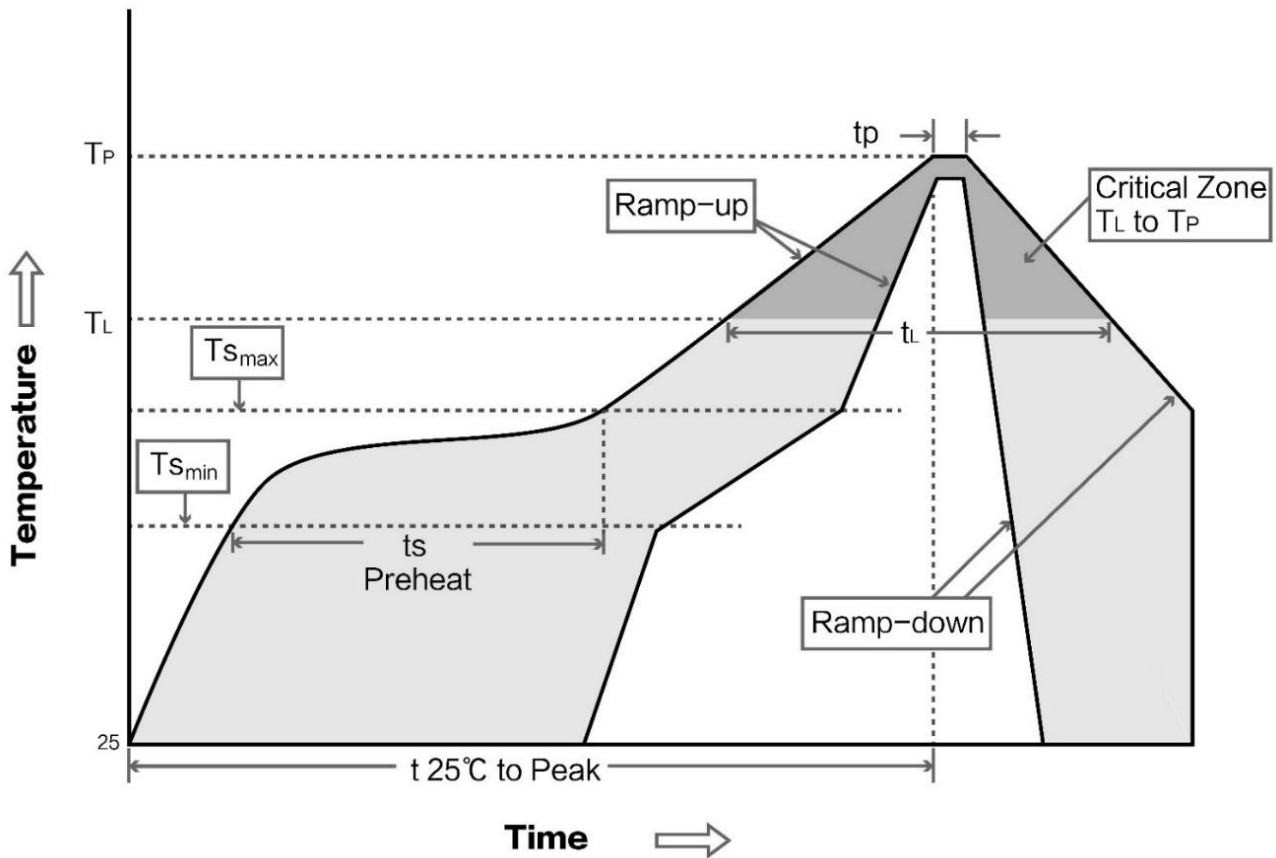

Chapter 13 E22 series

Model No.	Chip	Frequency Hz	Tx power dBm	Tested Distance km	Package	Size mm	Communication Interface
E22-400T22S	SX1268	433/470M	22	5	SMD	16*26	UART
E22-400T22D	SX1268	433/470M	22	5	DIP	21*36	UART
E22-400T30S	SX1268	433/470M	30	10	SMD	20*40.5	UART
E22-400T30D	SX1268	433/470M	30	10	DIP	24*43	UART
E22-900T22S	SX1262	868/915M	22	5	SMD	16*26	UART
E22-900T22D	SX1262	868/915M	22	5	DIP	21*36	UART
E22-900T30S	SX1262	868/915M	30	10	SMD	20*40.5	UART
E22-900T30D	SX1262	868/915M	30	10	DIP	24*43	UART
E22-400T33D	SX1268	433/470M	33	12	DIP	37*60	UART

Chapter 14 Antenna recommendation

14.1 Antenna recommendation

The antenna is an important role in the communication process. A good antenna can largely improve the communication system. Therefore, we recommend some antennas for wireless modules with excellent performance and reasonable price.

Model No.	Type	Frequency Hz	Interface	Gain dBi	Height	Cable length cm	Function & Feature
TX433-NP-4310	FPC antenna	433M	焊接	2.0	43.8*9.5	-	Embedded FPC antenna
TX433-JZ-5	Rubber antenna	433M	SMA-J	2.0	52	-	Short straight & omnidirectional
TX433-JZG-6	Rubber antenna	433M	SMA-J	2.5	62	-	Short straight & omnidirectional
TX433-JW-5	Rubber antenna	433M	SMA-J	2.0	50	-	Flexible & omnidirectional
TX433-JWG-7	Rubber antenna	433M	SMA-J	2.5	75	-	Flexible & omnidirectional
TX433-JK-11	Rubber	433M	SMA-J	2.5	110	-	Flexible & omnidirectional

	antenna						
TX433-JK-20	Rubber antenna	433M	SMA-J	3.0	210	-	Flexible & omnidirectional
TX433-XPL-100	Sucker antenna	433M	SMA-J	3.5	185	100	Small sucker antenna, cost-effective
TX433-XP-200	Sucker antenna	433M	SMA-J	4.0	190	200	Medium sucker antenna, low power consumption
TX433-XPB-300	Sucker antenna	433M	SMA-J	6.0	965	300	Large sucker antenna, high gain
TX490-JZ-5	Sucker antenna	470/490M	SMA-J	2.0	50	-	Short straight & omnidirectional
TX490-XPL-100	Sucker antenna	470/490M	SMA-J	3.5	120	100	Small sucker antenna, cost-effective

Revision history

Version	Date	Description	Issued by
1.0	2022-12-30	Initial version	Yan
1.1	2023-2-2	Bug fixes	Yan
1.2	2023-4-10	Bug fixes	Yan

About us

Technical support: support@cdebyte.com

Documents and RF Setting download link: <https://www.cdebyte.com>

Thank you for using Ebyte products! Please contact us with any questions or suggestions: info@cdebyte.com

 Official hotline: 028-61543675

Web: <https://www.cdebyte.com>

Address: , Building B5, Mould Industrial Park, 199# Xiqu Ave, High-tech Zone, Chengdu, 611731, Sichuan, China



Chengdu Ebyte Electronic Technology Co., Ltd.