



E28-2G4M12XX User Manual

SX1281 2.4GHz SPI SMD High Speed LoRa Module



Contents

1. Overview	2
1.1 Brief introduction	2
1.2 Features	2
1.3 Application	2
2. Specification and parameter	3
2.1 Limit parameter	3
2.2 Operating parameter	3
3. Size and pin definition	4
4. Basic operation	6
4.1 Hardware design	6
4.2 Software editing	6
5. Basic application	7
5.1 Basic circuit diagram	7
6. FAQ	7
6.1 Communication range is too short	7
6.2 Module is easy to damage	8
6.3 BER(Bit Error Rate) is high	8
7. Production guidance	8
7.1 Reflow soldering temperature	8
7.2 Reflow soldering curve	9
8. E28 Series	9
9. Antenna guidance	10
9.1 Antenna recommendation	10
9.2 Antenna selection	10
Revision history	11
About us	11

1. Overview

1.1 Brief introduction

E28-2G4M12S/SX is a 2.4GHz bluetooth module designed by Chengdu Ebyte, with long distance and ultra-low power consumption. E28-2G4M12S is small-sized SMD module (pin spacing 1.27mm), built-in PCB antenna and IPEX antenna. High precision 52MHz crystal is used.

Based on the original imported RF chip SX1281 from SEMTECH, it features multiple physical layers and various modulating methods such as LoRa, FLRC and GFSK, the special modulating methods and processing ways enable longer operating range under LoRa and FLRC modulating methods, and the GFSK method covers BLE protocol. The outstanding ultra-low power consumption and the DC-DC and Time-of-Flight on chip make the chip much more capable for smart home, security system, tracking and locating, wireless distance measuring, wearable electronics, smart bracelet and health management & etc. SX1281 supports RSSI, users need to conduct a secondary development based on their own demands; SX1281 also integrates time of flight for ranging functions.

Since the module is a pure RF transceiver module, you need to use the MCU driver or a dedicated SPI debug tool.

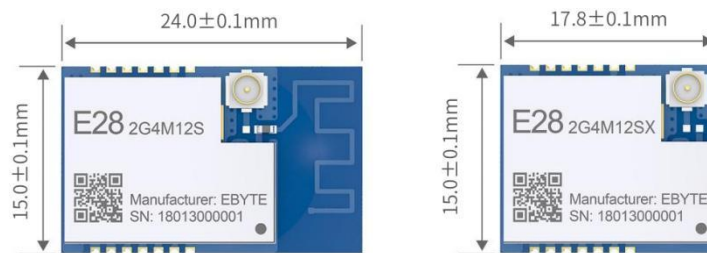

1.2 Features

- Communication distance tested is up to 3km;
- Maximum transmission power of 18mW, software multi-level adjustable;
- Compatible with BLE protocol;
- Support the global license-free ISM 2.4GHz band;
- Support air data rate of 0.476kbps ~ 2Mbps;
- Support multiple modulation methods, (GFSK Mode, FLRC Mode, LoRa Mode);
- Support 1.8V~3.6V power supply, power supply over 3.3V can guarantee the best performance;
- Industrial grade standard design, support -40 ~ 85 °C for working over a long time;
- IPEX and PCB antenna optional, good for secondary development and integration;
- The air data rate is adjustable, the maximum air data rate is up to 1.3 Mbps in FLRC mode;
- Excellent anti-blocking properties;
- Ranging, with Time-of-flight function.

1.3 Application

- Home security alarm and remote keyless entry;
- Smart home and industrial sensors;
- Wireless alarm security system;
- Building automation solutions;

- Wireless industrial-grade remote control;
- Health care products;
- Advanced Meter Reading Architecture(AMI);
- Automotive industry applications.

2.Specification and parameter

2.1 Limit parameter

Main parameter	Performance		Remark
	Min.	Max.	
Power supply (V)	0	3.6	Voltage over 3.6V will cause permanent damage to module
Blocking power (dBm)	-	10	Chances of burn is slim when modules are used in short distance
Operating temperature (°C)	-40	85	/

2.2 Operating parameter

Main parameter		Performance			Remark
		Min.	Typ.	Max.	
Operating voltage (V)		1.8	3.3	3.6	≥3.3 V ensures output power
Communication level (V)			3.3		For 5V TTL, it may be at risk of burning down
Operating temperature (°C)		-40	-	85	Industrial design
Operating frequency (MHz)		2400	2430	2500	Support ISM band
Power consumption	TX current (mA)		45		Instant power consumption
	RX current (mA)		10		
	Sleep current (μA)		2.0		Software is shut down
Max Tx power (dBm)		12	12.5	14	
Receiving sensitivity (dBm)		-128	-	-130	LoRa receiver sensitivity with CR=4/5 and high sensitivity mode enabled 1SF12,BW=203kHz
Air data rate	LoRa (bps)	0.595k~253.9k			Programming
	FLRC (bps)	E28-2G4M12S:260k E28-2G4M12SX:1.3M			Programming
	GFSK (bps)	125k~2M			Programming

Main parameter	Description		Remark
Model	E28-2G4M12S	E28-2G4M12SX	
Distance for reference	3000m	3000m	Test condition: clear and open area, antenna gain: 5dBi, antenna height: 2.5m, air data rate: 1kbps

FIFO	256Byte	256Byte	Max length transmitted each time
Crystal frequency	52MHz	52MHz	
Modulation	LoRa™ (recommended)	LoRa™ (recommended)	GFSK Mode , FLRC Mode, LoRa Mode
Package	SMD	SMD	
Connector	1.27mm	1.27mm	
Communication interface	SPI	SPI	0-10Mbps
Size	25* 14 mm	17.8* 15 mm	
Antenna	IPEX/PCB	IPEX	50 ohm impedance
Weight	1.6±0.1g	1.1±0.1g	

3.Size and pin definition

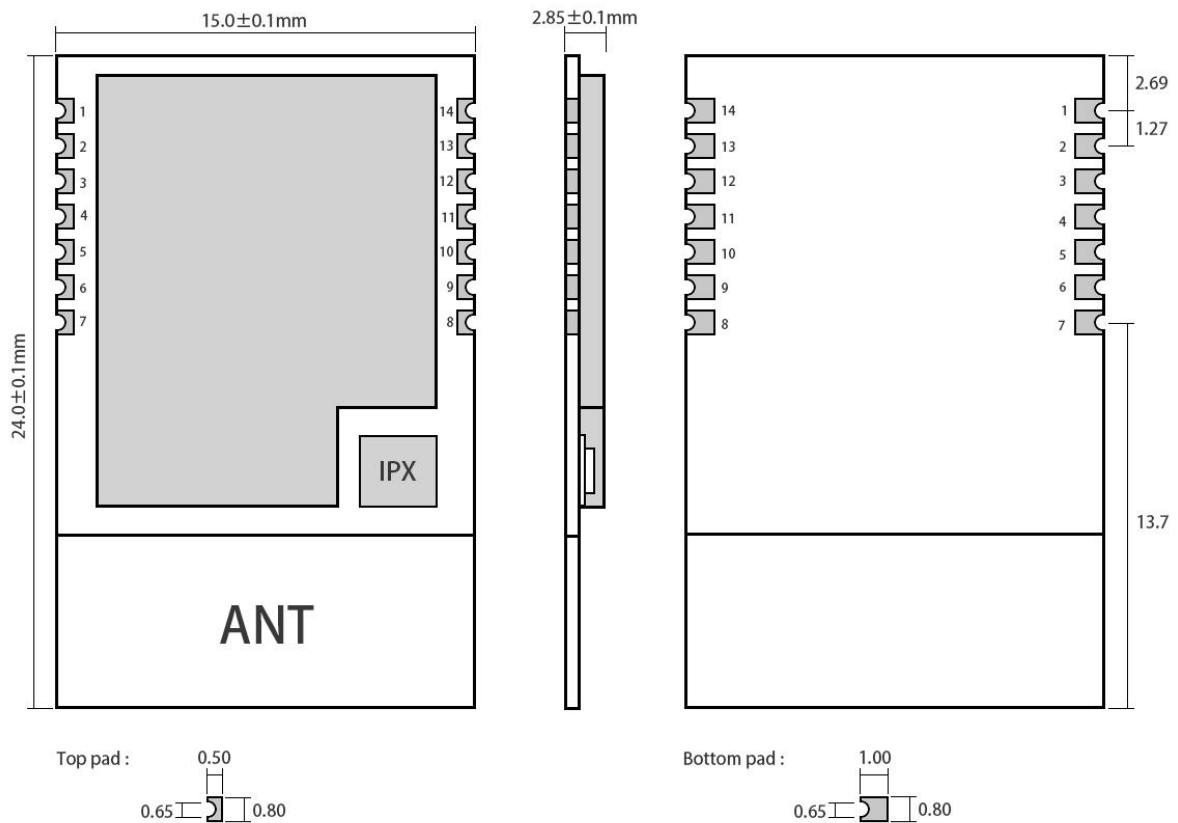

Pad quantity : 14
Unit: mm

E28-2G4M12S

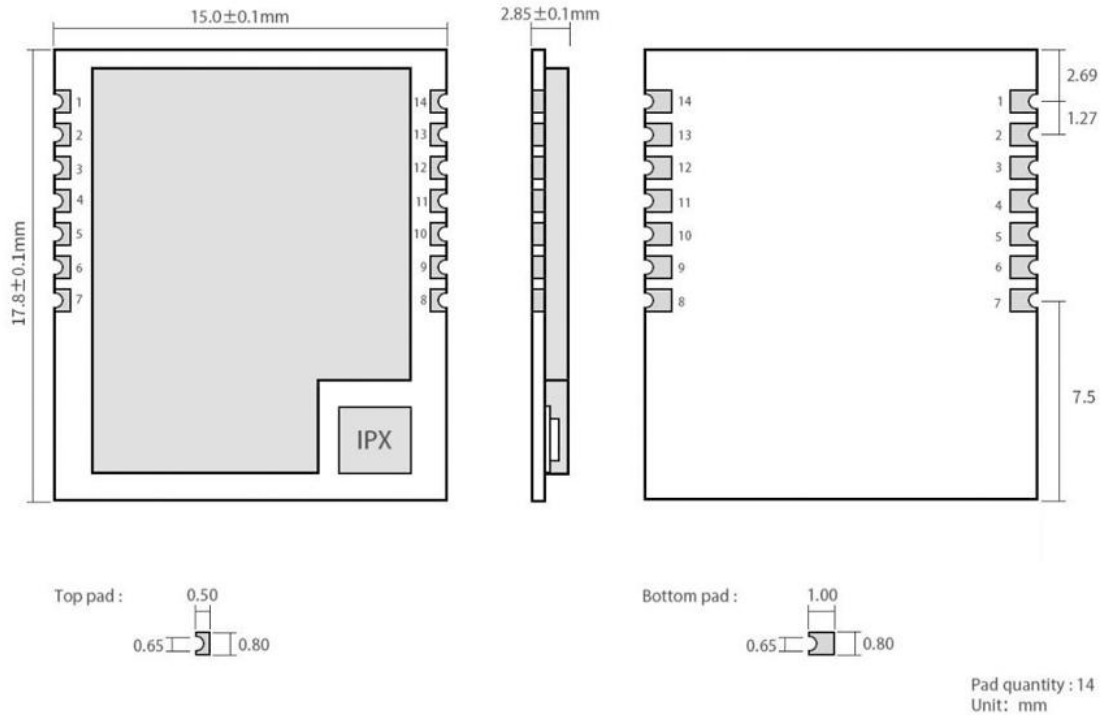

E28-2G4M12SX

Pin No	Pin item	Pin direction	Pin application
1	VCC		Power supply: 1.8~3.6V (Ceramic filter capacitor is advised to add)
2	GND		Ground, connecting to power supply reference ground
3	MISO_TX	Output	SPI data output pin, can be used as UART transmitting pin
4	MOSI_RX	Input	SPI data input pin, can be used as UART receiving pin
5	SCK_RTSN	Input	SPI clock input pin, can be used as UART request transmitting pin
6	NSS_CTS	Input	Module chip selection pin, used to start a SPI communication; and can be used as UART clearing transmitting pin (refer to SX1281 Datasheet)
7	GND		Ground, connecting to power supply reference ground
8	GND		Ground, connecting to power supply reference ground
9	NRESET	Input	Chip reset initiation input pin, valid under low level, built-in 50k pull-up resistor
10	BUSY	Output	Status indication (refer to SX1281 Datasheet)
11	DIO1	Input / Output	Configurable IO port (Please find more on SX1281 datasheet)
12	DIO2	Input / Output	Configurable IO port (Please find more on SX1281 datasheet)
13	DIO3	Input / Output	Configurable IO port (Please find more on SX1281 datasheet)
14	GND		Ground, connecting to power supply reference ground

4. Basic operation

4.1 Hardware design

- It is recommended to use a DC stabilized power supply. The power supply ripple factor is as small as possible, and the module needs to be reliably grounded.;
- Please pay attention to the correct connection of the positive and negative poles of the power supply. Reverse connection may cause permanent damage to the module;
- Please check the power supply to ensure it is within the recommended voltage otherwise when it exceeds the maximum value the module will be permanently damaged;
- Please check the stability of the power supply, the voltage can not be fluctuated frequently;
- When designing the power supply circuit for the module, it is often recommended to reserve more than 30% of the margin, so the whole machine is beneficial for long-term stable operation.;
- The module should be as far away as possible from the power supply, transformers, high-frequency wiring and other parts with large electromagnetic interference.;
- High-frequency digital routing, high-frequency analog routing, and power routing must be avoided under the module. If it is necessary to pass through the module, assume that the module is soldered to the Top Layer, and the copper is spread on the Top Layer of the module contact part(well grounded), it must be close to the digital part of the module and routed in the Bottom Layer;
- Assuming the module is soldered or placed over the Top Layer, it is wrong to randomly route over the Bottom Layer or other layers, which will affect the module's spurs and receiving sensitivity to varying degrees;
- It is assumed that there are devices with large electromagnetic interference around the module that will greatly affect the performance. It is recommended to keep them away from the module according to the strength of the interference. If necessary, appropriate isolation and shielding can be done;
- Assume that there are traces with large electromagnetic interference (high-frequency digital, high-frequency analog, power traces) around the module that will greatly affect the performance of the module. It is recommended to stay away from the module according to the strength of the interference. If necessary, appropriate isolation and shielding can be done.
- If the communication line uses a 5V level, a 1k-5.1k resistor must be connected in series (not recommended, there is still a risk of damage);
- Try to stay away from some physical layers such as TTL protocol at 2.4GHz , for example: USB3.0;
- The mounting structure of antenna has a great influence on the performance of the module. It is necessary to ensure that the antenna is exposed, preferably vertically upward. When the module is mounted inside the case, use a good antenna extension cable to extend the antenna to the outside;
- The antenna must not be installed inside the metal case, which will cause the transmission distance to be greatly weakened.

4.2 Software editing

- This module is based on SX1281, same drive way as SX1281, user can refer to SX1281 datasheet.
- GDO 0 is general I/O port, see more in SX1281 datasheet.
- GDO 2 is generally configured as IRQ function, IRQ pin can also be disconnected. The SPI query mode can be

used to obtain the interrupt status. However, it is recommended to use the external interrupt of the MCU.

- After SX1281 restores IDLE mode or configures sleep mode, it is recommended that the power configuration table be reinitialized.

5. Basic application

5.1 Basic circuit diagram

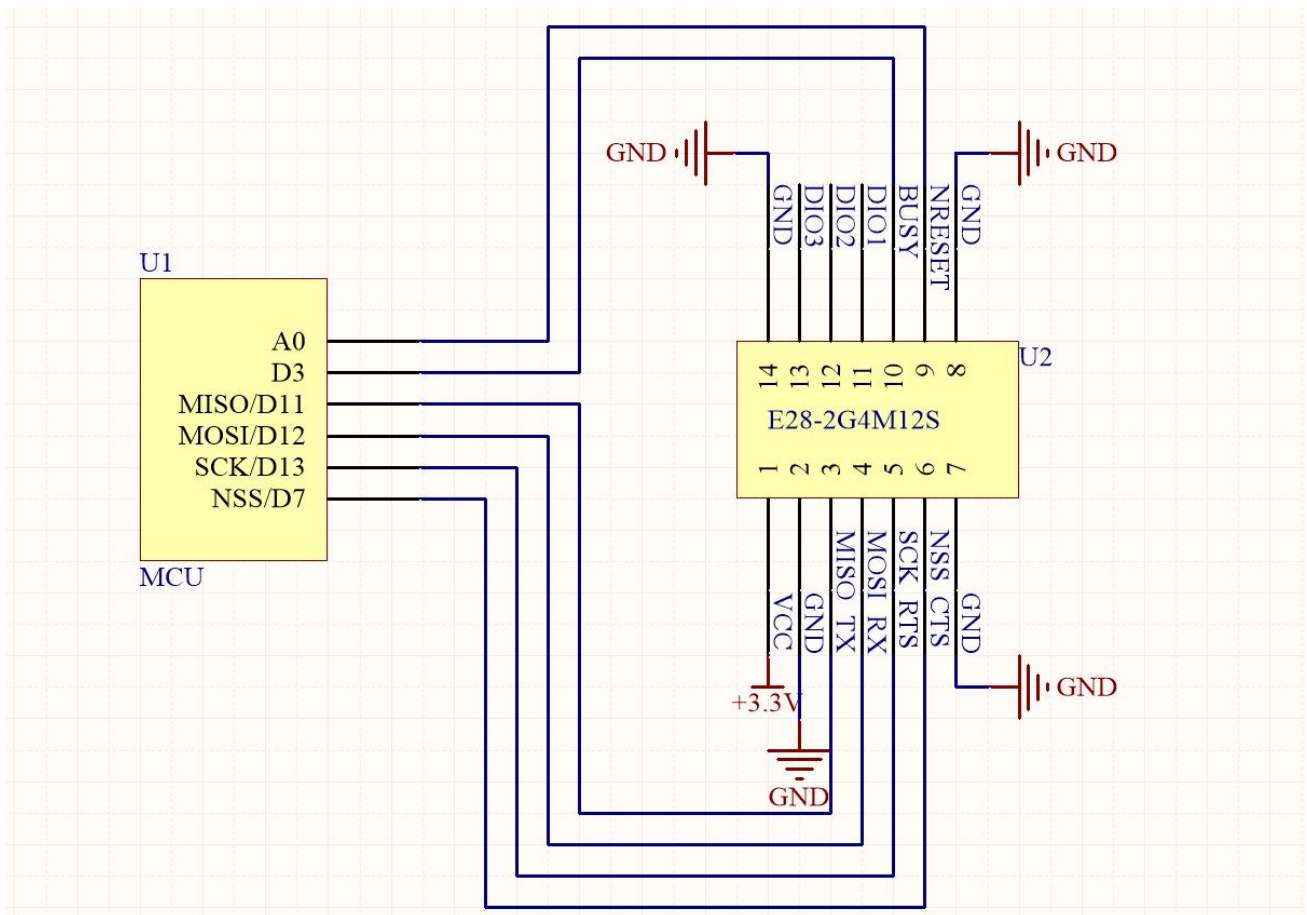

6. FAQ

6.1 Communication range is too short

- The communication distance will be affected when obstacle exists.
- Data lose rate will be affected by temperature, humidity and co-channel interference.
- The ground will absorb and reflect wireless radio wave, so the performance will be poor when testing near ground.
- Sea water has great ability in absorbing wireless radio wave, so performance will be poor when testing near the sea.
- The signal will be affected when the antenna is near metal object or put in a metal case.

- Power register was set incorrectly, air data rate is set as too high (the higher the air data rate, the shorter the distance).
- The power supply low voltage under room temperature is lower than 2.5V, the lower the voltage, the lower the transmitting power.
- Due to antenna quality or poor matching between antenna and module.

6.2 Module is easy to damage

- Please check the power supply source, ensure it is within right voltage range.
- Please check the stability of power source, the voltage cannot fluctuate too much.
- Please make sure antistatic measure are taken when installing and using, high frequency devices have electrostatic susceptibility.
- Please ensure the humidity is within limited range, some parts are sensitive to humidity.
- Please avoid using modules under too high or too low temperature.

6.3 BER(Bit Error Rate) is high

- There are co-channel signal interference nearby, please be away from interference sources or modify frequency and channel to avoid interference;
- Poor power supply may cause messy code. Make sure that the power supply is reliable.
- The extension line and feeder quality are poor or too long, so the bit error rate is high;

7. Production guidance

7.1 Reflow soldering temperature

Profile Feature	Sn-Pb Assembly	Pb-Free Assembly
Solder Paste	Sn63/Pb37	Sn96.5/Ag3/Cu0.5
Preheat Temperature min (T _{smin})	100°C	150°C
Preheat temperature max (T _{smax})	150°C	200°C
Preheat Time (T _{smin} to T _{smax})(t _s)	60-120 sec	60-120 sec
Average ramp-up rate(T _{smax} to T _p)	3°C/second max	3°C/second max
Liquidous Temperature (TL)	183°C	217°C
Time (t _L) Maintained Above (TL)	60-90 sec	30-90 sec
Peak temperature (T _p)	220-235°C	230-250°C
Average ramp-down rate (T _p to T _{smax})	6°C/second max	6°C/second max
Time 25°C to peak temperature	max 6 minutes	max 8 minutes

7.2 Reflow soldering curve

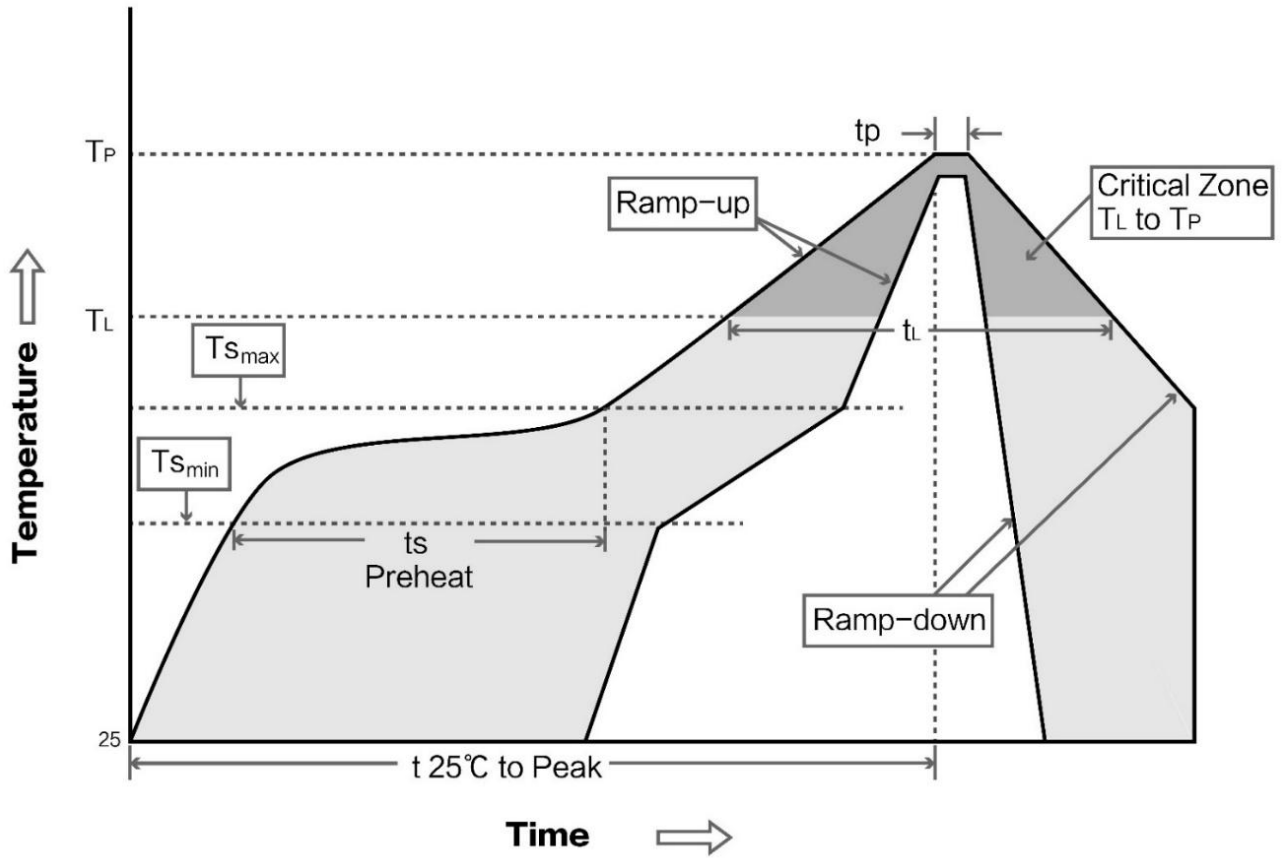

8.E28 Series

Model No.	IC	Frequency (Hz)	Tx power (dBm)	Test distance (km)	Package	Size	Communication interface
E28-2G4T12S	SX1280	2.4G	12.5	3	SMD	17.5* 28.7	TTL
E28-2G4M27S	SX1281	2.4G	27	8	SMD	15*26.5	SPI
E28-2G4M20S	SX1281	2.4G	20	6	SMD	15 * 26.5	SPI
E28-2G4M12S	SX1281	2.4G	12.5	3	SMD	25*14	SPI

9. Antenna guidance

9.1 Antenna recommendation

The antenna is an important role in the communication process. A good antenna can largely improve the communication system. Therefore, we recommend some antennas for wireless modules with excellent performance and reasonable price.

Model No.	Type	Frequency Hz	Interface	Gain dBi	Height	Cable	Function feature
TX2400-NP-5010	FCB antenna	2.4G	SMA-J	2	50*10mm	-	FPC soft antenna
TX2400-XPL-150	Sucker	2.4G	SMA-J	3.5	15cm	150cm	Sucker antenna, High gain
TX2400-JK-20	Rubber	2.4G	SMA-J	3	200mm	-	Flexible & omnidirectional
TX2400-JK-11	Rubber	2.4G	SMA-J	2.5	110mm	-	Flexible & omnidirectional
TX2400-JZ-3	Rubber	2.4G	SMA-J	2	30mm	-	Short straight & omnidirectional

9.2 Antenna selection

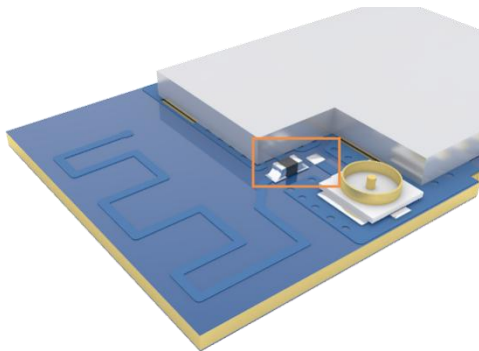

PCB (default)

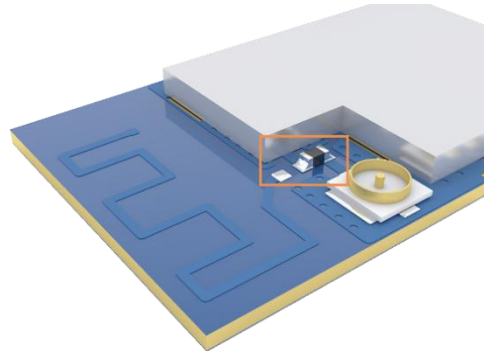

IPEX

Revision history

Version	Date	Description	Issued by
1.0	2023-6-14	Initial version	huaa
1.1	2018-5-23	Content updated	huaa
1.2	2018-9-18	Model No. split	huaa
1.3	2019-2-17	Content updated	Ray
1.4	2019-04-04	Content updated	Ray
1.6	2020-06-10	Overall dimension modification	du
1.7	2023-06-14	New combined model	Liu
1.8	2024-2-22	Content updated	Hao
1.9	2024-4-18	Modified ranging description	Hao
2.0	2024-7-19	Content updated	LAU

About us

Technical support: support@cdebyte.com

Documents and RF Setting download link: www.ebyte.com

Thank you for using Ebyte products! Please contact us with any questions or suggestions: info@cdebyte.com

 Official hotline:028-61399028

Web: www.cdebyte.com

Address: , Building B5, Mould Industrial Park, 199# Xiqu Ave, High-tech Zone, Chengdu, 611731, Sichuan, China



