



E49-400M20S Usermanual

CMT2300A 433MHz/470MHz SMD Module



Contents

1. Overview	3
1.1 Brief Introduction	4
1.2 Key Features	4
1.3 Application	4
2.0 Specification and Parameter	5
2.1 Limit parameter	5
2.2 Working Parameters	5
3.0 Size and pin definition	6
4.0 Hardware and Software Notice	7
4.1 Hardware Notice	7
4.2 Software Notice	7
5.0 Basic Circuit Diagram	8
6.0 FAQ	9
6.1 Communication range is too short	9
6.2 Module is easy to damage	9
6.3 BER(Bit Error Rate) is high	9
7.0 Guide for Soldering work	10
7.1 Reflow soldering temperature	10
7.2 Reflow soldering curve	10
8.0 Similar Products with CMT2300A	11
9.0 Recommendation for Antennas	11
Revision history	12
About us	12

Disclaimer and copyright notice

The information in this article, including the URL for reference, is subject to change without notice. The document is provided "as is" without warranty of any kind, including any warranty of merchantability, fitness for a particular purpose or non-infringement, and any warranty of any proposal, specification or sample referred to elsewhere. This document does not bear any liability, including any infringement of any patent rights resulting from the use of the information contained in this document. No estoppel or other license, express or implied, is granted herein for the use of intellectual property.

All the test data obtained in this paper are obtained by E-Baite laboratory, and the actual results may be slightly different.

It is hereby declared that all trade names, trade marks and registered trade marks mentioned herein are the property of their respective owners.

The right of final interpretation belongs to Chengdu Yibaite Electronic Technology Co., LTD.

The attention

The contents of this manual may change due to product version upgrade or other reasons. E-baite Electronic Technology Co., Ltd. reserves the right to modify the contents of this manual without any notice or prompt. This manual is only used as a guide, and Chengdu Yibaite Electronic Technology Co., Ltd. makes every effort to provide accurate information in this manual, but Chengdu Yibaite Electronic Technology Co., Ltd. does not guarantee that the content of this manual is completely free of errors, and all statements, information and Suggestions in this manual do not constitute any express or implied warranty.

1. Overview

1.1 Brief Introduction

E49-400M20S is a cost-effective wireless data transmission module launched by Chengdu Ebyte. It is a pure hardware module based on CMT2300A.

E49-400M20S supports a maximum transmit power of 20dBm, and users can set a lower output power to save power consumption. The module works in the 410MHz ~ 510MHz frequency band, covering the commonly used 433MHz and 470MHz frequency bands. Since this module is a pure RF transceiver module, it uses an SPI interface and requires an MCU driver.



1.2 Key Features

- The measured communication distance can reach 2.5km;
- The maximum transmit power is 20dBm, and the software can be adjusted in multiple levels;
- Support ISM 433MHz/470MHz frequency band;
- Support data transmission rate from 0.5Kbps to 300Kbps;
- Support low power consumption mode, suitable for battery applications;
- Support GFSK modulation and OOK and (G)MSK;
- Support 2.6V~3.6V power supply;
- Industrial grade standard design, support long-term use at -40~85°C;
- Support stamp hole and IPEX interface, users can choose to use according to their own needs.

1.3 Application

- Smart home and industrial sensors, etc.;
- Security system, positioning system;
- Wireless remote control, UAV;
- Wireless game remote control;
- Healthcare products;
- Wireless voice, wireless headset;
- Automotive industry applications.

2.0 Specification and Parameter

2.1 Limit parameter

Table 2-1 Limit parameter table

Main parameter	Performance		Remark
	Min.	Max.	
Power supply (V)	0	3.6	Voltage over 3.6V will cause permanent damage to module
Operating temperature (°C)	-40	85	/

2.2 Working Parameters

Table 2-2 Limit parameter table

Main parameter		Performance			Remark
		Min.	Typ.	Max.	
Operating voltage (V)		1.8	3.3	3.6	Over 3.6V may permanently burn the module
Communication level (V)		-	3.3	-	Using 5V level has the risk of burning
Operating temperature (°C)		-40	-	+85	Industrial grade
Operating frequency (MHz)		410	433	510	-
Power consumption	TX current (mA)	-	85	@Transmit power 20dBm	Instant power consumption
	RX current (mA)	-	8.5	-	
	Sleep current (µA)	-	0.1	-	Software is shut down
Max Tx power (dBm)		-	20	-	-
Receiving sensitivity (dBm)		-116	-117	-118	@Air rate is 1.2kbps

Main parameter	Description	Remark
Reference distance	2.5km	Clear and open, antenna height 2.5 meters, air rate 2.4kbps
Crystal frequency	26MHz	-
Packaging method	SMD	-
Communication Interface	SPI	-
Dimensions	20*14mm	-
RF interface	IPEX/stamp hole	Equivalent impedance is about 50Ω
product weight	1.2±0.1g	Clear and open, antenna height 2.5 meters, air rate 2.4kbps

3.0 Size and pin definition

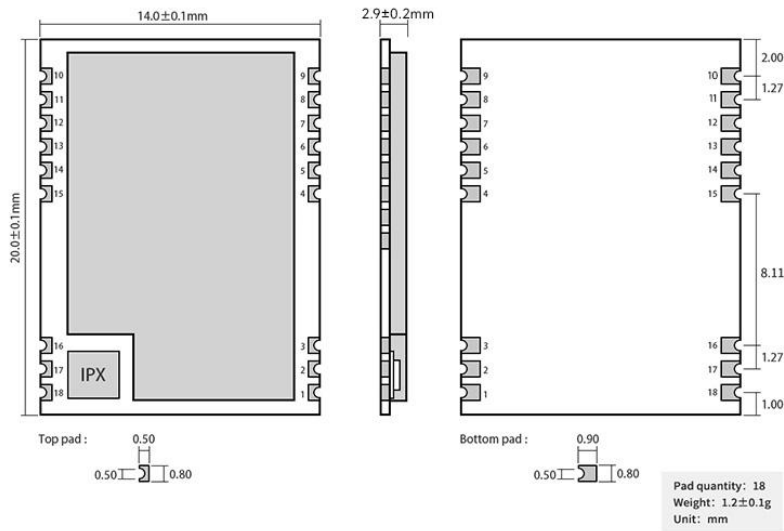

Image 3-1 Mechanical Dimensions and Pin Definition

Chart 3-1 Pin definition table

No.	Name	Direction	Function
1	GND	-	Ground wire, connect to power reference ground
2	GND	-	Ground wire, connect to power reference ground
3	GND	-	Ground wire, connect to power reference ground
4	GND	-	Ground wire, connect to power reference ground
5	GPIO1	DI/O	Configurable multi-function IO port (see CMT2300A manual for details)
6	GPIO2	DI/O	Configurable multi-function IO port (see CMT2300A manual for details)
7	GPIO3	DI/O	Configurable multi-function IO port (see CMT2300A manual for details)
8	VCC	-	Module power supply, connect to power supply +3.3V
9	GND	-	Ground wire, connect to power reference ground
10	GND	-	Ground wire, connect to power reference ground
11	SCLK	DI	SPI clock pin
12	SDIO	DI/O	SPI data pins
13	CSB	DI	Chip select for SPI access register
14	FCSB	DI	Chip select for SPI access to FIFO
15	GND	-	Ground wire, connect to power reference ground
16	GND	-	Ground wire, connect to power reference ground
17	ANT	-	Module RF stamp hole interface, equivalent impedance is about 50Ω
18	GND	-	Ground wire, connect to power reference ground

4.0 Hardware and Software Notice

4.1 Hardware Notice

- It is recommended to use a DC stabilized power supply to supply power to the module. The power supply ripple coefficient is as small as possible, and the module needs to be reliably grounded
- Please pay attention to the correct connection of the positive and negative poles of the power supply, such as reverse connection may cause permanent damage to the module;
- Please check the power supply to ensure that it is between the recommended power supply voltage, if exceeding the maximum value will cause permanent damage to the module;
- Please check the power supply stability, the voltage cannot fluctuate significantly and frequently;
- When designing the power supply circuit for the module, it is often recommended to reserve more than 30% of the margin, so that the whole machine is conducive to long-term stable work;
- The module should be as far away as possible from the power supply, transformer, high-frequency wiring and other parts with large electromagnetic interference;
- High-frequency digital traces, high-frequency analog traces, and power traces must be avoided under the module. If it is absolutely necessary to pass under the module, it is assumed that the module is soldered to the Top Layer, and copper is laid on the Top Layer of the module contact part (all copper And well grounded), must be close to the digital part of the module and the wiring is on the Bottom Layer;
- Assuming that the module is soldered or placed on the Top Layer, it is also wrong to randomly route on the Bottom Layer or other layers, which will affect the module's spurs and receiving sensitivity to varying degrees;
- It is assumed that there are devices with large electromagnetic interference around the module that will greatly affect the performance of the module. It is recommended to stay away from the module according to the intensity of the interference. If the situation permits, proper isolation and shielding can be done;
- It is assumed that there are traces with high electromagnetic interference around the module (high-frequency digital, high-frequency analog, and power traces), which will greatly affect the performance of the module. It is recommended to stay away from the module according to the intensity of the interference. Isolation and shielding;
- Try to stay away from the TTL protocol which is also 2.4GHz in some physical layers, for example: USB3.0;
- The antenna installation structure has a great impact on the performance of the module. Make sure that the antenna is exposed, preferably vertically. When the module is installed inside the chassis, you can use high-quality antenna extension cords to extend the antenna to the outside of the chassis;
- The antenna must not be installed inside the metal shell, which will greatly weaken the transmission distance.

4.2 Software Notice

- The chip of this module is CMT2300A, and its driving mode is SPI, and users can operate according to the [CMT2300A chip Datasheet](#).
- GPIO1/GPIO2/GPIO3 are general-purpose I/O ports, see [CMT2300A Datasheet](#) for details.

5.0 Basic Circuit Diagram

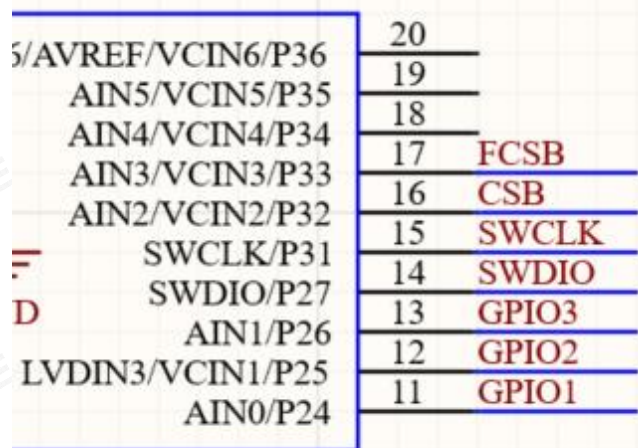
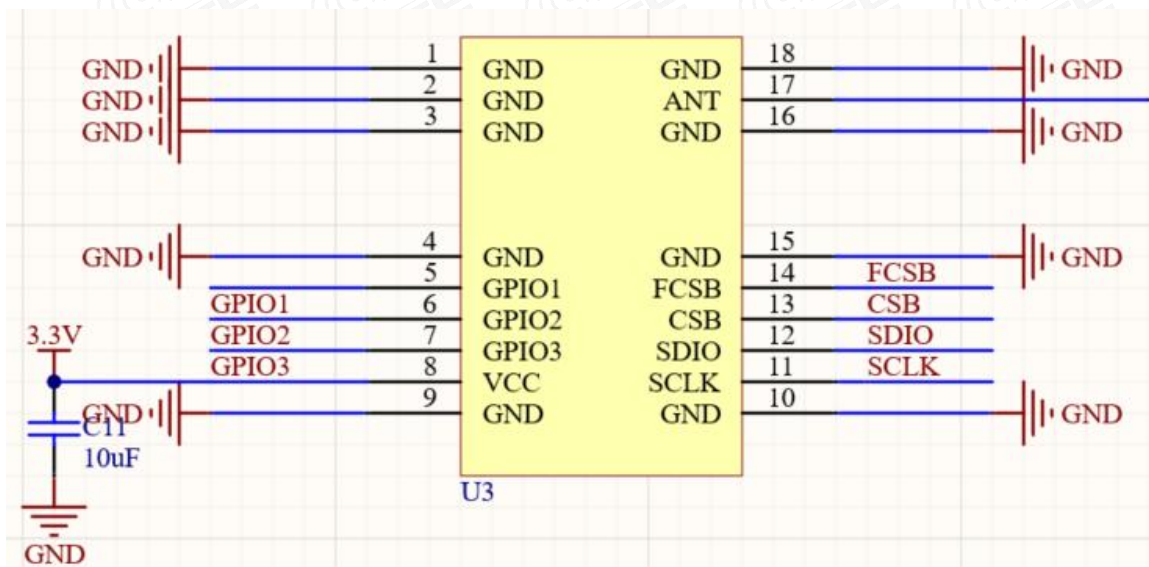
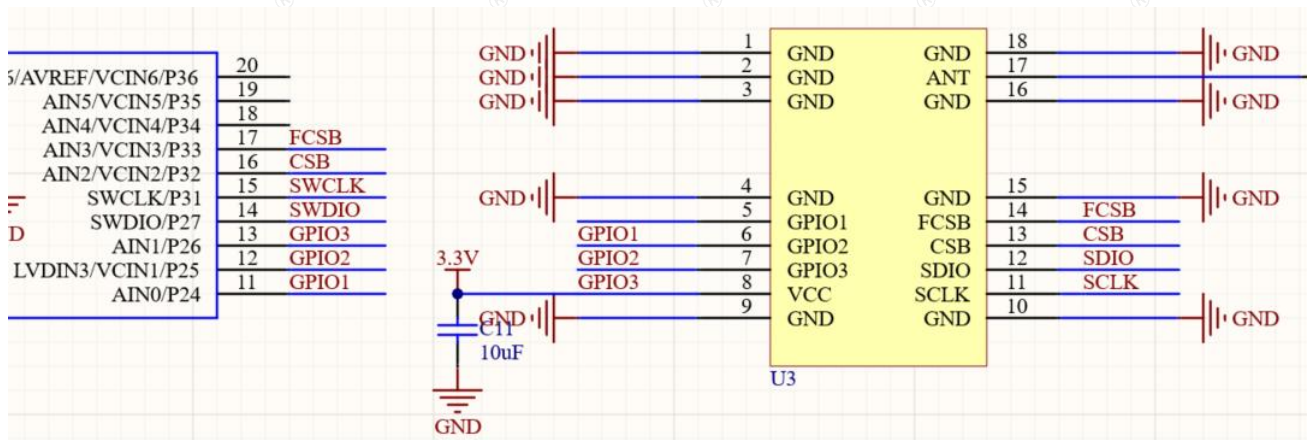

Chart 5-1 circuit diagram

6.0 FAQ

6.1 Communication range is too short

- The communication distance will be affected when obstacle exists.
- Data lose rate will be affected by temperature, humidity and co-channel interference.
- The ground will absorb and reflect wireless radio wave, so the performance will be poor when testing near ground.
- Sea water has great ability in absorbing wireless radio wave, so performance will be poor when testing near the sea.
- The signal will be affected when the antenna is near metal object or put in a metal case.
- Power register was set incorrectly, air data rate is set as too high (the higher the air data rate, the shorter the distance).
- The power supply low voltage under room temperature is lower than 2.5V, the lower the voltage, the lower the transmitting power.
- Due to antenna quality or poor matching between antenna and module.

6.2 Module is easy to damage

- Please check the power supply source, ensure it is 2.0V~3.6V, voltage higher than 3.6V will damage the module.
- Please check the stability of power source, the voltage cannot fluctuate too much.
- Please make sure antistatic measure are taken when installing and using, high frequency devices have electrostatic susceptibility.
- Please ensure the humidity is within limited range, some parts are sensitive to humidity.
- Please avoid using modules under too high or too low temperature.

6.3 BER(Bit Error Rate) is high

- There are co-channel signal interference nearby, please be away from interference sources or modify frequency and channel to avoid interference;
- Poor power supply may cause messy code. Make sure that the power supply is reliable.
- The extension line and feeder quality are poor or too long, so the bit error rate is high;

7.0 Guide for Soldering work

7.1 Reflow soldering temperature

Profile Feature	Curve characteristics	Sn-Pb Assembly	Pb-Free Assembly
Solder Paste	Solder paste	Sn63/Pb37	Sn96.5/Ag3/Cu0.5
Preheat Temperature min (T _{smin})	Min preheating temp.	100°C	150°C
Preheat temperature max (T _{smax})	Mx preheating temp.	150°C	200°C
Preheat Time (T _{smin} to T _{smax})(t _s)	Preheating time	60-120 sec	60-120 sec
Average ramp-up rate(T _{smax} to T _p)	Average ramp-up rate	3°C/second max	3°C/second max
Liquidous Temperature (TL)	Liquid phase temp.	183°C	217°C
Time (t _L) Maintained Above (TL)	Time below liquid phase line	60-90 sec	30-90 sec
Peak temperature (T _p)	Peak temp.	220-235°C	230-250°C
Average ramp-down rate (T _p to T _{smax})	Average ramp-down rate	6°C/second max	6°C/second max
Time 25°C to peak temperature	Time to peak temperature for 25°C	max 6 minutes	max 8 minutes

7.2 Reflow soldering curve

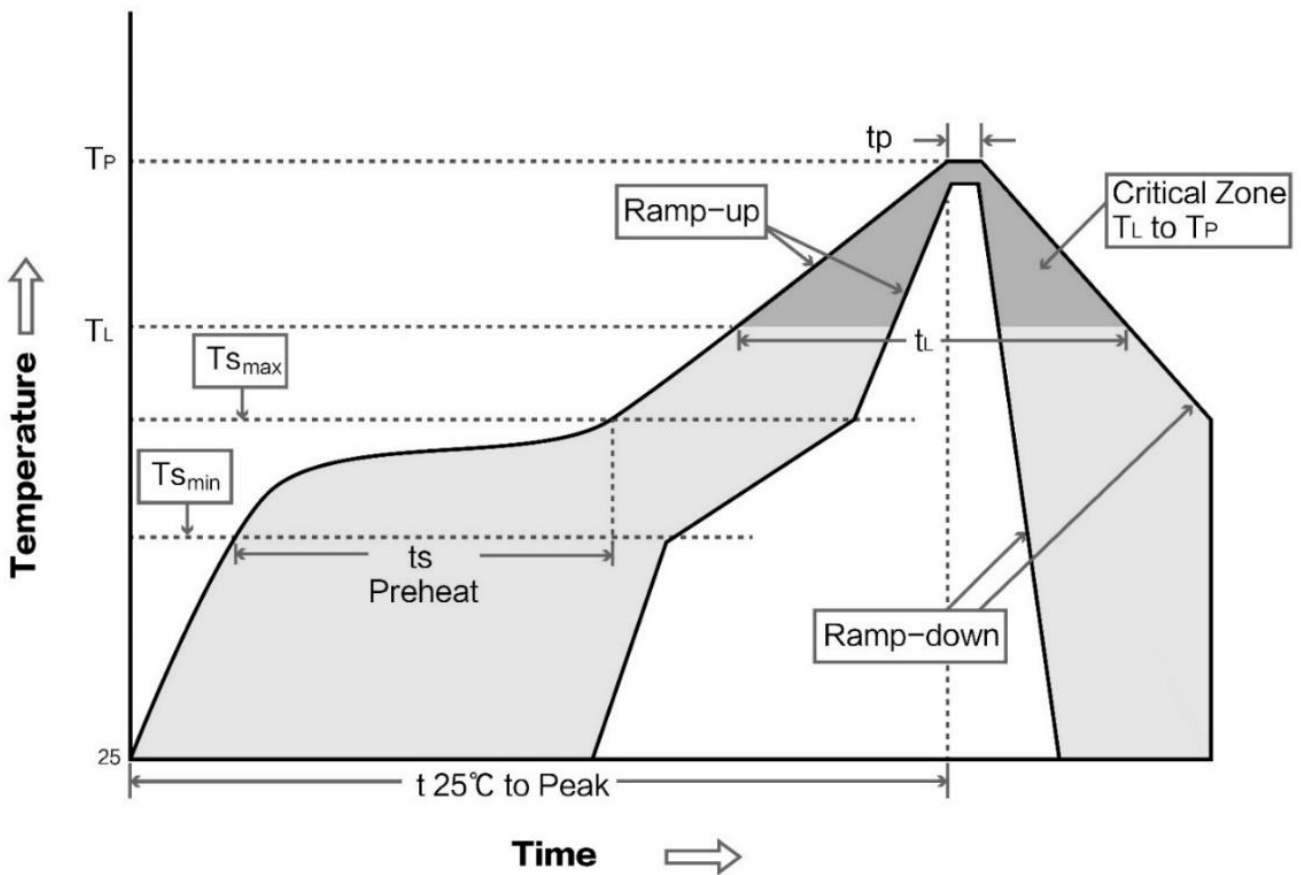

8.0 Similar Products with CMT2300A

Model	Chip	Freq.	Tx Power	Range	Dim.	Package Type	Interface
		Hz	dBm	km	mm		
E49-400T20S	CMT2300A	410~450MHz	20	1	26*16	SMD	UART
E49-400T20D	CMT2300A	410~450MHz	20	1	36*21	DIP	UART

9.0 Recommendation for Antennas

The antenna is very important for the RF module, and the antenna performance will have a great impact on the communication system. Therefore, we recommend you below antennas which are suitable for Ebyte modules with excellent performance and reasonable price:

Please search the model and see more antenna details on:<http://www.ebyte.com/en/product-class.aspx?key=TX>

Model	Type	Freq.	Gain	Dim.	Cable Length		Features
		Hz	dBi	mm	cm		
TX433-JW-5	Rubber antenna	433M	2	50mm	-	SMA-J	Bendable, omnidirectional
TX433-JWG-7	Rubber antenna	433M	2.5	75mm	-	SMA-J	Bendable, omnidirectional
TX433-JK-20	Rubber antenna	433M	3	210mm	-	SMA-J	Bendable, omnidirectional
TX433-JK-11	Rubber antenna	433M	2.5	110mm	-	SMA-J	Bendable, omnidirectional
TX433-XP-200	Magnetic base antenna	433M	4	19cm	200cm	SMA-J	magnet base, high gain
TX433-XP-100	Magnetic base antenna	433M	3.5	18.5cm	100cm	SMA-J	magnet base, high gain
TX433-XP-300	Magnetic base antenna	433M	6	96.5cm	300cm	SMA-J	magnet base, ultra high gain
TX433-JZG-6	Rubber antenna	433M	2.5	52mm	-	SMA-J	Ultra short straight, omnidirectional
TX433-JZ-5	Rubber antenna	433M	2	52mm	-	SMA-J	Ultra short straight, omnidirectional
TX490-XP-100	Magnetic base antenna	490M	50	12cm	100cm	SMA-J	magnet base, high gain
TX490-JZ-5	Rubber antenna	490M	50	50mm	-	SMA-J	Ultra short straight, omnidirectional

Revision history

Version	Date	Remark	By
1.0	2020-05-28	First version	Huaa
1.1	2020-11-16	Parameter correction	Linson
1.2	2021-6-10	Parameter correction	Linson
1.3	2021-6-23	Error correction	Linson
1.4	2024-3-22	Error correction	Lau

About us

Technical support: support@cdebyte.com

Documents and RF Setting download link: <https://www.cdebyte.com>

Thank you for using Ebyte products! Please contact us with any questions or suggestions: info@cdebyte.com

Fax: 028-64146160

Web: www.ebyte.com

Address: B5 Mould Industrial Park, 199# Xiqu Ave, High tech Zone, Chengdu, Sichuan, China



Chengdu Ebyte Electronic Technology Co.,Ltd.