



E72-2G4M23S1A

CC2630 ZigBee 6LoWPAN SMD Wireless Module



目录

1 Introduction	2
1.1 Brief Introduction.....	2
1.2 Features	2
1.3 Application	2
2 Specification and parameter	3
2.1 Limit parameter	3
2.2 Operating parameter	3
3 Size and pin definition	4
4 Basic operation.....	6
4.1 Hardware design.....	6
4.2 Programming.....	6
4.3 Connection instructions to the emulator.....	7
5 FAQ.....	8
5.1 Communication range is too short	8
5.2 Module is easy to damage.....	8
5.3 BER(Bit Error Rate) is high	8
6 Production guidance.....	9
6.1 Reflow soldering temperature	9
6.2 Reflow soldering curve	9
7 E72 series	10
8 Antenna recommendation.....	10
8.1 Recommendation.....	10
8.1 Antenna switch	11
Revision history	11
About us	11

1 Introduction

1.1 Brief Introduction

E72-2G4M05S1A is a self-developed, small-size, SMD, ZigBee 6LoWPAN 100mw wireless module based on CC2630 of Texas Instruments.

The CC2630 integrates 128KB of in-system programmable flash memory, 8KB of buffered static RAM (SRAM) and ZigBee, 6LoWPAN wireless communication protocol. Because of its unique ultra-low power sensor controller, it is ideal for connecting external sensors. The analog and digital data are collected autonomously while the rest of the system is in sleep mode. Thanks to its built-in dual-core low-power processor, users can build a complete system based on their own modules. We used a 24MHz industrial grade high precision low temperature drift active crystal.

Since this module is a SoC module, it needs to be programmed by user before it can be used.

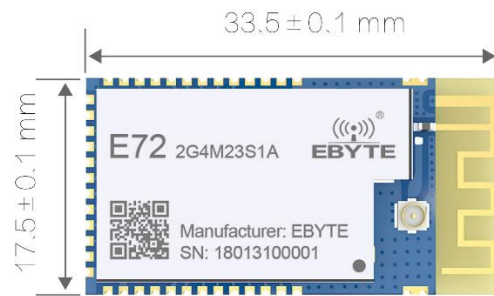

1.2 Features

- The measured communication distance can reach 150m/500m;
- Maximum transmission power of 3.2 mW, software multi-level adjustable;
- Built-in ZigBee, 6LoWPAN protocol stack;
- Built-in 32.768kHz clock crystal oscillator;
- Support the global license-free ISM 2.4 GHz band;
- Built-in high performance low power consumption Cortex-M3 and Cortex-M0 dual core processor;
- Rich resources, 128KB FLASH, 28KB RAM;
- Support 1.8V~3.6V power supply, power supply over 3.3 V can guarantee the best performance;
- Industrial grade standard design, support -40 ~ 85 °C for working over a long time;
- IPEX and stamp hole optional, good for secondary development and integration.

1.3 Application

- Home security alarm and remote keyless entry;
- Wireless alarm security system;
- Building automation solutions;
- Wireless industrial-grade remote control;
- Health care products;
- Advanced Meter Reading Architecture(AMI);
- Automotive industry applications.

2 Specification and parameter

2.1 Limit parameter

Main parameter	Performance		Remark
	Min	Max	
Power supply (V)	0	3.8	Voltage over 3.6V will cause permanent damage to module
Blocking power (dBm)	-	10	Chances of burn is slim when modules are used in short distance
Operating temperature (°C)	-40	85	-

2.2 Operating parameter

Main parameter	Performance			Remark
	Min	Type	Max	
Operating voltage (V)	1.8	3.3	3.8	≥3.3 V ensures output power
Communication level (V)	-	3.0	-	For 5V TTL, it may be at risk of burning down
Operating temperature (°C)	-40	-	85	Industrial grade
Operating frequency (MHz)	2.402	-	2.480	Support ISM band
Power Consumption	TX current (mA)	-	182.5	Instant power consumption
	RX current (mA)	-	11.1	-
	Sleep current (μA)	-	1.4	Shut down by software
Max TX power (dBm)	22.6	23.0	23.2	-
Receiving sensitivity (dBm)	-100.5	-102.0	-103.5	Air data rate is 250 kbps
Air data rate (bps)	250k	-	1M	Controlled via user's programming

Main parameter	Description	Remark
Reference distance	500m/1500m	Test condition: clear and open area, antenna gain: 5dBi, antenna height: 2.5m, air data rate: 250 kbps
Crystal Oscillator	24MHz / 32.768KHz	-
Protocol	ZigBee	-
Package	SMD	-
Interface	1.27mm	-
IC	CC2630F128RGZR	-
FLASH	128 KB	-

RAM	28 KB	-
Core	Cortex-M3 + Cortex-M0	-
Size	17.5 * 33.5 mm	-
Antenna	PCB / IPEX	50 ohm impedance

3 Size and pin definition

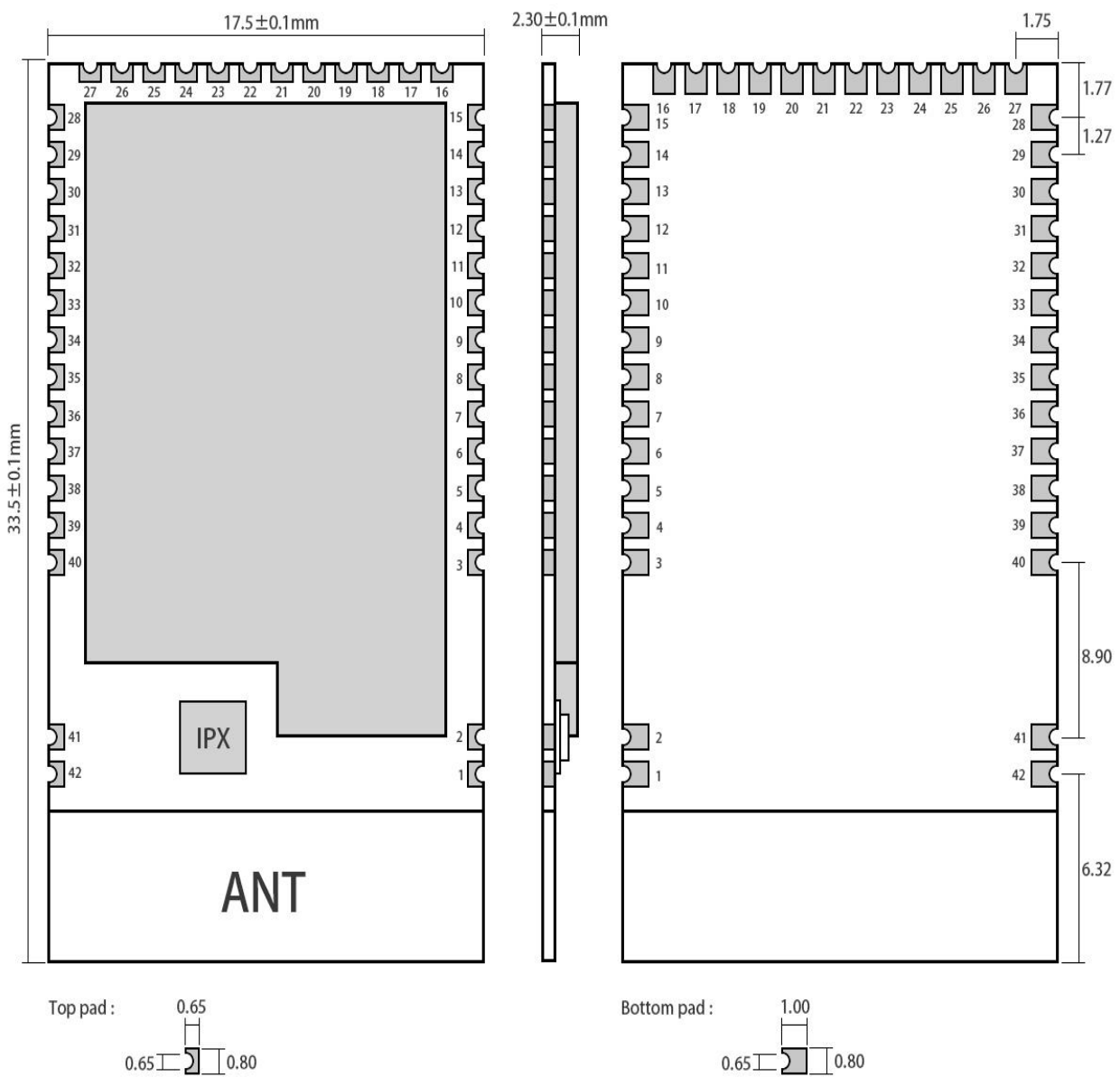

Pad quantity : 42
Unit: mm

Pin No.	Item	Direction	Description
1、 2、 3	GND	-	Ground
4	DIO_0	Input/Output	General IO port, sensor controller (see CC26xx manual for details)
5	DIO_1	Input/Output	General IO port, sensor controller (see CC26xx manual for details)
6	DIO_2	Input/Output	General IO port, sensor controller (see CC26xx manual for details)
7	DIO_3	Input/Output	General IO port, sensor controller (see CC26xx manual for details)
8	DIO_4	Input/Output	General IO port, sensor controller (see CC26xx manual for details)
9	DIO_5	Input/Output	High drive General IO port, sensor controller (see CC26xx manual for details)
10	DIO_6	Input/Output	High drive General IO port, sensor controller (see CC26xx manual for details)
11	DIO_7	Input/Output	High drive General IO port, sensor controller (see CC26xx manual for details)
12	DIO_8	Input/Output	General IO port (see CC26xx manual for details)
13	DIO_9	Input/Output	General IO port (see CC26xx manual for details)
14	DIO_10	Input/Output	General IO port (see CC26xx manual for details)
15	DIO_11	Input/Output	General IO port (see CC26xx manual for details)
16	DIO_12	Input/Output	General IO port (see CC26xx manual for details)
17	DIO_13	Input/Output	General IO port (see CC26xx manual for details)
18	DIO_14	Input/Output	General IO port (see CC26xx manual for details)
19	DIO_15	Input/Output	General IO port (see CC26xx manual for details)
20	JTAG_TMS	Input/Output	JTAG_TMSC, High drive (see CC26xx manual for details)
21	JTAG_TCK	Input/Output	JTAG_TCKC, High drive (see CC26xx manual for details)
22	DIO_16	Input/Output	High drive General IO port, JTAG_TDO (see CC26xx manual for details)
23	DIO_17	Input/Output	High drive General IO port, JTAG_TDI (see CC26xx manual for details)
24	DIO_18	Input/Output	General IO port (see CC26xx manual for details)
25	DIO_19	Input/Output	General IO port (see CC26xx manual for details)
26	DIO_20	Input/Output	General IO port (see CC26xx manual for details)
27	GND	-	Ground
28	DIO_21	Input/Output	General IO port (see CC26xx manual for details)
29	VDD	-	Power supply, 1.8V - 3.6V
30	DIO_22	Input/Output	General IO port (see CC26xx manual for details)
31	DIO_23	Input/Output	General IO port, sensor controller, Digital and analog (see CC26xx manual for details)
32	nRESET	Input	Reset, low level (see CC26xx manual for details)
33	DIO_24	Input/Output	General IO port, sensor controller, Digital and analog (see CC26xx manual for details)
34	DIO_25	Input/Output	General IO port, sensor controller, Digital and analog (see CC26xx manual for details)
35	DIO_26	Input/Output	General IO port, sensor controller, Digital and analog (see CC26xx manual for details)
36	DIO_27	Input/Output	General IO port, sensor controller, Digital and analog (see CC26xx manual for details)
37	DIO_28	Input/Output	General IO port, sensor controller, Digital and analog (see CC26xx manual for details)
38	DIO_29	Input/Output	General IO port, sensor controller, Digital and analog (see CC26xx manual for details)
39	DIO_30	Input/Output	General IO port, sensor controller, Digital and analog (see CC26xx manual for details)
40、 41、 42	GND	-	Ground

4 Basic operation

4.1 Hardware design

- It is recommended to use a DC stabilized power supply. The power supply ripple factor is as small as possible and the module needs to be reliably grounded;
- Please pay attention to the correct connection of the positive and negative poles of the power supply, reverse connection may cause permanent damage to the module;
- Please check the power supply to ensure that between the recommended supply voltage, if exceeding the maximum, the module will be permanently damaged;
- Please check the stability of the power supply. Voltage can not fluctuate greatly and frequently;
- When designing the power supply circuit for the module, it is often recommended to reserve more than 30% of the margin, so the whole machine is beneficial for long-term stable operation;
- The module should be as far away as possible from the power supply, transformers, high-frequency wiring and other parts with large electromagnetic interference;
- Bottom Layer High-frequency digital routing, high-frequency analog routing, and power routing must be avoided under the module. If it is necessary to pass through the module, assume that the module is soldered to the Top Layer, and the copper is spread on the Top Layer of the module contact part (well grounded), it must be close to the digital part of the module and routed in the Bottom Layer;
- Assuming the module is soldered or placed over the Top Layer, it is wrong to randomly route over the Bottom Layer or other layers, which will affect the module's spurs and receiving sensitivity to varying degrees;
- It is assumed that there are devices with large electromagnetic interference around the module that will greatly affect the performance. It is recommended to keep them away from the module according to the strength of the interference. If necessary, appropriate isolation and shielding can be done;
- Assume that there are traces with large electromagnetic interference (high-frequency digital, high-frequency analog, power traces) around the module that will greatly affect the performance of the module. It is recommended to stay away from the module according to the strength of the interference. If necessary, appropriate isolation and shielding can be done;
- If the communication line uses a 5V level, a 1k-5.1k resistor must be connected in series (not recommended, there is still a risk of damage);
- Try to stay away from some physical layers such as TTL protocol at 2.4GHz, for example: USB3.0;
- The mounting structure of antenna has a great influence on the performance of the module. It is necessary to ensure that the antenna is exposed, preferably vertically upward. When the module is mounted inside the case, use a good antenna extension cable to extend the antenna to the outside;
- The antenna must not be installed inside the metal case, which will cause the transmission distance to be greatly weakened.

4.2 Programming

- The core of this module is CC2630, its driving method is completely equivalent to CC2630, the user can operate according to the CC2630 chip manual (see CC2630 manual for details);

- It is recommended to use the Code Composer Studio (CCS) Integrated Development Environment (IDE).
- Code Composer Studio is an integrated development environment (IDE) that supports TI's microcontroller and embedded processor products. Code Composer Studio includes a complete set of tools for developing and debugging embedded applications. It includes the C/C++ compiler, source editor, project build environment, debugger, descriptor, and many other features. The IDE provides a single user interface to help you through every step of the application development process. Familiar tools and interfaces allow users to get started faster than ever before. Code Composer Studio combines the benefits of the Eclipse software framework with TI's advanced embedded debugging capabilities to provide embedded developers with a compelling, feature-rich development environment.
 - ★ When transmitting, set DIO_7 pin to high level and DIO_13, DIO_14 pins to low level;
 - ★ When receiving, set DIO_7 pin to low level and DIO_13, DIO_14 pins to high level;
 - ★ Before turning off, set DIO_7, DIO_13, DIO_14 pins to low;
- The register configuration can be reinitialized when the chip is idle for greater stability.

4.3 Connection instructions to the emulator

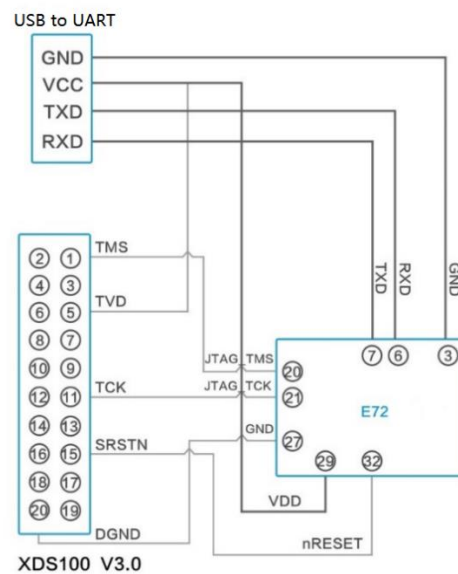

- TMS, TCK, reset, and ground need to be connected between the emulator and the module, and an additional 3.3V power supply is required for the emulator;
- Use USB to UART module to connect with module, module serial port and IO port are multiplexed, users can set according to their own needs;
- Please note that good grounding is required. When there is a large area of grounding, the power supply ripple is small. Increase the filter capacitor and try to be close to the VCC and GND pins of the module.

5 FAQ

5.1 Communication range is too short

- The communication distance will be affected when obstacle exists;
- Data lose rate will be affected by temperature, humidity and co-channel interference;
- The ground will absorb and reflect wireless radio wave, so the performance will be poor when testing near ground;
- Sea water has great ability in absorbing wireless radio wave, so performance will be poor when testing near the sea;
- The signal will be affected when the antenna is near metal object or put in a metal case;
- Power register was set incorrectly, air data rate is set as too high (the higher the air data rate, the shorter the distance);
- The power supply low voltage under room temperature is lower than 2.5V, the lower the voltage, the lower the transmitting power;
- Due to antenna quality or poor matching between antenna and module.

5.2 Module is easy to damage

- Please check the power supply source, ensure it is 2.0V~3.6V, voltage higher than 3.6V will damage the module;
- Please check the stability of power source, the voltage cannot fluctuate too much;
- Please make sure antistatic measure are taken when installing and using, high frequency devices have electrostatic susceptibility;
- Please ensure the humidity is within limited range, some parts are sensitive to humidity;
- Please avoid using modules under too high or too low temperature.

5.3 BER(Bit Error Rate) is high

- There are co-channel signal interference nearby, please be away from interference sources or modify frequency and channel to avoid interference;
- Poor power supply may cause messy code. Make sure that the power supply is reliable;
- The extension line and feeder quality are poor or too long, so the bit error rate is high.

6 Production guidance

6.1 Reflow soldering temperature

Profile Feature	Curve characteristics	Sn-Pb Assembly	Pb-Free Assembly
Solder Paste	Solder paste	Sn63/Pb37	Sn96.5/Ag3/Cu0.5
Preheat Temperature min (T _{smin})	M in preheating temp.	100°C	150°C
Preheat temperature max (T _{smax})	Mx preheating temp.	150°C	200°C
Preheat Time (T _{smin} to T _{smax})(t _s)	Preheating time	60-120 sec	60-120 sec
Average ramp-up rate(T _{smax} to T _p)	Average ramp-up rate	3°C/second max	3°C/second max
Liquidous Temperature (TL)	Liquid phase temp.	183°C	217°C
Time (t _L) Maintained Above (TL)	Time below liquid phase line	60-90 sec	30-90 sec
Peak temperature (T _p)	Peak temp.	220-235°C	230-250°C
Average ramp-down rate (T _p to T _{smax})	Average ramp-down rate	6°C/second max	6°C/second max
Time 25°C to peak temperature	Time to peak temperature for 25°C	6 minutes max	8 minutes max

6.2 Reflow soldering curve

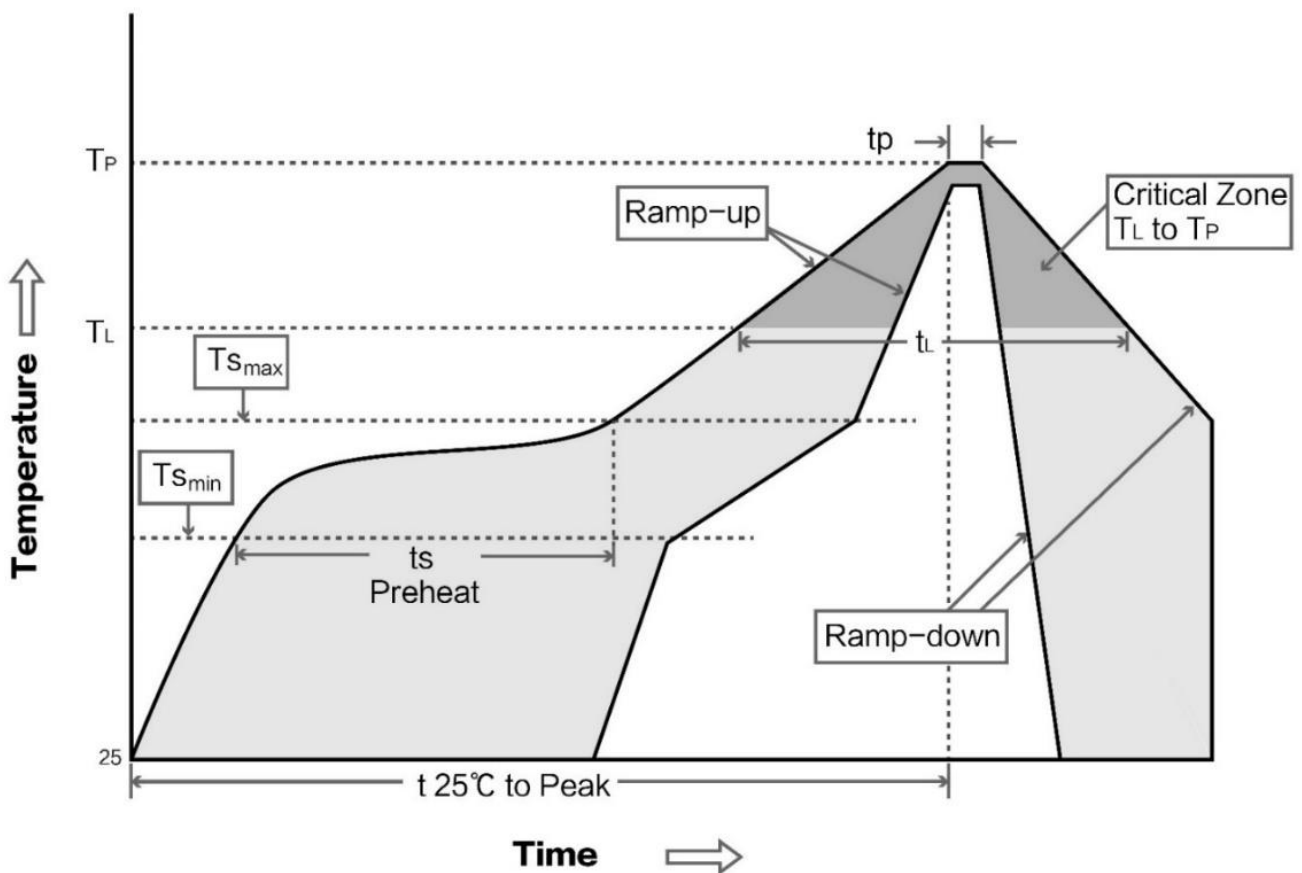

7 E72 series

ModelNo.	IC	Frequency Hz	Tx power dBm	Distance km	Protocol	Package	Size mm	Antenna
E72-2G4M23S1A	CC2630	2.4G	23	1.5	-	SMD	17.5 * 33.5	PCB/IPEX
E72-2G4M05S1A	CC2630	2.4G	5	0.5	-	SMD	17.5 * 28.7	PCB/IPEX
E72-2G4M02S2B	CC2640	2.4G	2	0.3	BLE 4.1	SMD	14 * 23	PCB/IPEX
E72-2G4M05S1B	CC2640	2.4G	5	0.5	BLE 4.2	SMD	17.5 * 28.7	PCB/IPEX

8 Antenna recommendation

8.1 Recommendation

The antenna is an important role in the communication process. A good antenna can largely improve the communication system. Therefore, we recommend some antennas for wireless modules with excellent performance and reasonable price.

ModelNo.	Type	Frequency Hz	Interface	Gain dBi	Height	Cable	Function feature
TX2400-NP-5010	Flexible Antenna	2.4G	IPEX	2	50*10mm	-	FPC soft antenna
TX2400-XP-150	Sucker antenna	2.4G	SMA-J	3.5	15cm	150cm	High gain
TX2400-JK-20	Rubber antenna	2.4G	SMA-J	3	200mm	-	Flexible & omnidirectional
TX2400-JK-11	Rubber antenna	2.4G	SMA-J	2.5	110mm	-	Flexible & omnidirectional
TX2400-JZ-3	Rubber antenna	2.4G	SMA-J	2	30mm	-	Short straight & omnidirectional

8.1 Antenna switch

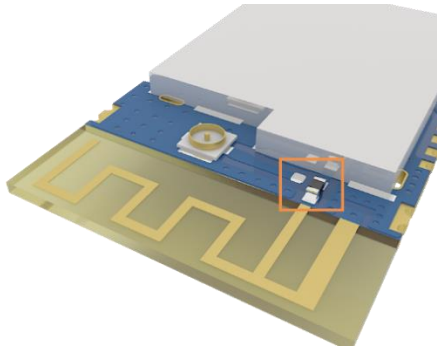

PCB antenna (default)

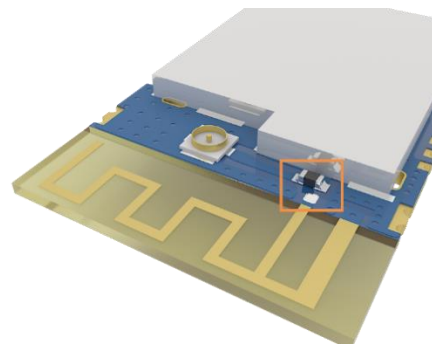

IPEX

Revision history

Version	Date	Description	Issued by
1.00	2018/8/30	Initial version	huaa
1.10	2018/9/28	Model No. split	huaa

About us

Technical support: support@cdebyte.com

Documents and RF Setting download link: www.ebyte.com

Thank you for using Ebyte products! Please contact us with any questions or suggestions: info@cdebyte.com

Fax: 028-64146160 ext. 821

Web: www.ebyte.com

Address: Innovation Center D347, 4# XI-XIN Road, Chengdu, Sichuan, China



Chengdu Ebyte Electronic Technology Co.,Ltd.