

GM61 Bar Code Reader Module User Manual

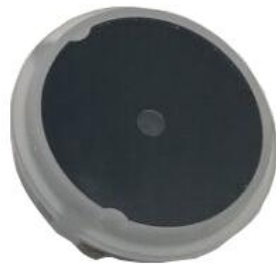

Hangzhou Grow Technology Co., Ltd.
V1.2 Nov.2021

Catalog

1 Introduction of Module	1
1.1 Introduction	1
1.2 Operating parameter	1
1.3 Size	2
1.4 Interface definition	3
1.5 Effect picture	3
2 Set Up GM61	4
2.1 Serial Port Instruction	4
2.1.1 Read Zone Bit	4
2.1.2 Write Zone Bit	6
2.1.3 Save Zone Bit To Internal Flash Instruction	7
2.1.4 Zone Bit Reset To Defaults	8
2.1.5 Program Erasure Operation	9
2.1.6 List of zone bit	11
2.2 Setup Code	15
2.3 Reset	15
3 Communication interface	16
3.1 Serial Communication Interface	16
3.1.1 Serial Port Check Bit Configuration	17
4 Read Mode	18
4.1 Continuous Mode	18
4.2 Induction Mode	19
4.3 Command Triggered Mode	21
5 Lighting and Prompt	23
6 Data Edition	26
6.1 Prefix	26
6.2 Suffix	27
6.3 CODE ID	28
6.4 Tail	29
6.5 Cut out Data	29

6.6 RF Information	31
6.7 Output Protocol	32
7 Bar code type enables/disable configuration	33
7.1 All types of bar code can be decoded	33
7.2 EAN-13	33
7.3 Code128	33
7.4 Code39	34
7.5 QR	34
8 Appendix A: Default Setting Table	35
9 Appendix B: Common serial port instruction	36
10 Appendix C: Code ID	37
11 Appendix D: ASCII	38
12 Appendix E: Data code	42
13 Appendix F: Save or Cancel	44

1 Introduction of Module

1.1 Introduction

GM61 Bar code reader module is a high integration and high performance scanner, mainly used to read payment codes. The bar code and QR code formats that can be recognized are **QR Code, Code 128, EAN 13, Code 39**.

1.2 Operating parameter

Parameter	Performance	
Scan Mode	640*480	
Light	Blue Light/ Green Light	
Read Code Type	1D	Code 128
		Code 39
		EAN13
	2D	QR code
Depth of Field*	EAN13(13mil)	40-80mm
	Code128(15mil)	30-160mm
	Code39(15mil)	40-155mm
	QR Code(15mil)	30-80mm
	Access Control Code (QR Code)	30-160mm (Adapt the phone screen code)
	Alipay Code(QR Code)	40-240mm ((Adapt the phone screen code)
Contrast*	≥30%	
Scanning angle**	Roll 360°, Pitch 45°, Yaw 45°	
Viewing Angle	55° (Inclination) , 42° (Elevation)	
Accuracy of reading*	QR ≥15mil can read, code39≥8mil	

Parameter	Performance
Interface	UART (TTL)
Serial Baud Rate (UART)	9600 (Default)
Voltage	3.3±5%(V)
Current	<100mA
Rated Power Consumption	0.85W
Size	Outside diameter: 21±0.1mm, Thickness 6.1±0.3 mm(Not including the connector)
Weight	<3g

Parameter	Performance
Work environment	-20°C - 60°C
Storage temperature	-40°C - 70°C
Environmental light	Direct exposure of normal indoor light source
Relative humidity	5%-95%
Working vibration	10-150HZ,0.5G,3 axial,1min/oct, 1 time/axial direction
Durable vibration	10-150HZ,2G,3 axial,1min/oct, 20 times/axial direction
Fall	Can withstand 1.2 meters of cement floor drop
IP level	Positive waterproof IP54

1.3 Size

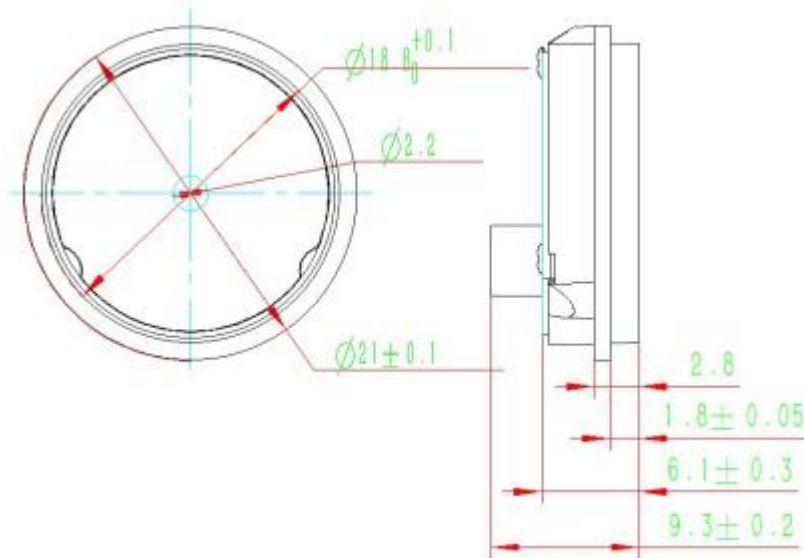

1.4 Interface definition

Socket: MX1.0mm,6Pin

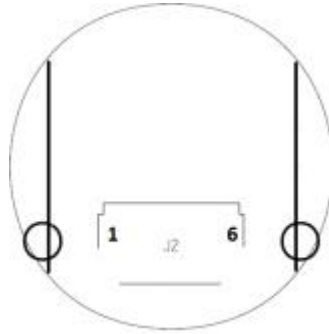

Pin Diagram

Pin	Name	Input/Output	Description
1	GND	Ground	Signal ground
2	RXD	Input	TTL Serial Receive Signal
3	TXD	Output	TTL Serial Send Signal
4	VCC3V3	Power	3.3V Power Supply
5	TRIG_OUT	NC	
6	VCC_3V3A	NC	

1.5 Effect picture



Front Effect



Light Effect



Side Effect

2 Set Up GM61

2.1 Serial Port Instruction

Users can settle the module by sending instruction from mainframe.

Please make sure communicate parameter complete matching between module and mainframe.

Module default serial communicate parameter: **Baud rate 9600bps; No check; 8 bit data; 1 bit stop bit; No flow control.**

2.1.1 Read Zone Bit

Max 255 bytes/time for zone bit reading.

Command Format:

Input: {Head1} {Types} {Lens} {Address} {Datas} {CRC}

PS: Head1: 0x7E 0x00 (2 bytes)

Types: 0x07 (1 byte)

Lens: 0x01 (1 byte)

Address : 0x0000~0x00FF (2 bytes) , address to start reading zone bit

Datas: 0x00~0xFF (1 byte) , Numbers of zone bit for Sequential read

CRC: CRC_CCITT check value (2 bytes). Suitable for Types、Lens、Address、Datas;

Characteristic polynomial : $X^{16}+X^{12}+X^5+1$, multinomial coefficient: 0x1021, original value:0 ;

For single byte, the highest bit will be calculated at first, output will be without negation.

The reference code of C is as follows:

```
unsigned int crc_cal_by_bit(unsigned char* ptr, unsigned int len)
{
    unsigned int crc = 0;
    while(len-- != 0)
    {
        for(unsigned char i = 0x80; i != 0; i /= 2)
        {
            crc *= 2;
            if((crc&0x10000) != 0) //Last CRC * 2 , if the first one is 1, so divide 0x11021
                crc ^= 0x11021;
            if(*ptr&i) != 0) //If the standard is 1, so CRC = last CRC + standard CRC_CCITT
                crc ^= 0x1021;
        }
    }
}
```

```

}
ptr++;
}
return crc;
}

```

Note: users can fill 0xAB 0xCD at CRC byte when CRC validation is not required.

Output: {Head2} {Types} {Lens} {Datas} {CRC}

1) Read successfully and return data

PS: Head2: 0x02 0x00

Types: 0x00 (read succeed)

Lens: numbers of upload bytes

Datas: 0x00~0xFF means read data.

CRC: CRC_CCITT check value. Suitable for Types、Lens、Datas;

Characteristic polynomial : $X^{16}+X^{12}+X^5+1$, multinomial coefficient: 0x1021, original value:0 ;

For single byte, the highest bit will be calculated at first, output will be without negation.

(The reference code is the same as above)

2) CRC failed

No response command

3) Unknown command response

No response command

E.G.:

Read address 0x000A of Zone bit

1) Read successfully and return data is 0x3E.

Input: 0x7E 0x00 0x07 0x01 0x00 0x0A 0x01 0xEE 0x8A

Output: 0x02 0x00 0x00 0x01 0x3E 0xE4 0xAC

2) CRC wrong

Input: 0x7E 0x00 0x07 0x01 0x00 0x0A 0x01 0x11 0x22

Output : None

3) When length of command to short or more than 400ms after 0x7e 0x00, treat as unknown command.

Input: 0x7E 0x00 0x07 0x01 0x00 0x0A 0x01

Output: None

2.1.2 Write Zone Bit

Max 255 bytes/time for zone bit reading.

The modified content of the zone bit will be lost after power failure. If the modified content is needed after power loss, You need to save the zone bit to internal Flash(2.1.3).

Command Format:

Input: {Head1} {Types} {Lens} {Address} {Datas} {CRC}

PS: Head1: 0x7E 0x00 (2 bytes)

Types: 0x08 (1 byte)

Lens: 0x00~0xFF (1 byte), means numbers of bytes of this datas, times of continuous writing.

Address: 0x0000~0xFFFF (2 bytes), start location of write

Datas: 0x00~0xFF (1~255 bytes), dates wrote in zone bit. When configuring multiple zone bit, must follow the order of address from low to high to fill the data domains.

CRC: CRC_CCITT check value (2 bytes). Suitable for Types、Lens、Address、Ddatas;

Characteristic polynomial : $X^{16}+X^{12}+X^5+1$, multinomial coefficient: 0x1021, original value:0 ;

For single byte, the highest bit will be calculated at first, output will be without negation.

The reference code of C is as follows:

```

unsigned int crc_cal_by_bit(unsigned char* ptr, unsigned int len)
{
    unsigned int crc = 0;
    while(len-- != 0)
    {
        for(unsigned char i = 0x80; i != 0; i /= 2)
        {
            crc *= 2;
            if((crc&0x10000) != 0) //Last CRC * 2, if the first one is 1, so divide 0x11021
                crc ^= 0x11021;
            if((*ptr&i) != 0) //If the standard is 1, so CRC = last CRC + standard CRC_CCITT
                crc ^= 0x1021;
        }
        ptr++;
    }
    return crc;
}
    
```

Note: users can fill 0xAB 0xCD at CRC byte when CRC validation is not required.

Output: {Head2} {Types} {Lens} {Ddatas} {CRC}

1) Read successfully

PS: Head2: 0x02 0x00

Types: 0x00 (read succeed)

Lens: 0x01

Datas: 0x00

CRC: CRC_CCITT check value (0x33 0x31)

2) CRC failed

No response command

3) Unknown command response

No response command

E.G.:

Write 0x3E in 0x000A of zone bit

1) Successfully set

Input : 0x7E 0x00 0x08 0x01 0x00 0x0A 0x3E 0x4C 0xCF

Output: 0x02 0x00 0x00 0x01 0x00 0x33 0x31

2) CRC wrong

Input: 0x7E 0x00 0x08 0x01 0x00 0x0A 0x3E 0x11 0x22

Output: None

3) When length of command to short or more than 400ms after 0x7e 0x00, treat as unknown command.

Input: 0x7E 0x00 0x08 0x01 0x00 0x0A 0x3E

Output: None

2.1.3 Save Zone Bit To Internal Flash Instruction

To save the device of the zone bit list to internal Flash, you need to send a save command.

Note: the device cannot save a single zone bit configuration separately, and must keep the entire list at the same time.

Command Format:

Input: {Head1} {Types} {Lens} {Address} {Datas} {CRC}

PS: Head1: 0x7E 0x00

Types: 0x09

Lens: 0x01

Address: 0x0000

Datas: 0x00

CRC: CRC_CCITT check value (0xDE 0xC8)

Output: {Head2} {Types} {Lens} {Datas} {CRC}

1) Saved successful

PS: Head2: 0x02 0x00

Types: 0x00 (read succeed)

Lens: 0x01

Datas: 0x00

CRC: CRC_CCITT check value (0x33 0x31)

2) CRC failed

No response command

3) Unknown command response

No response command

2.1.4 Zone Bit Reset To Defaults

Command Format:

Input: {Head1} {Types} {Lens} {Address} {Datas} {CRC}

PS: Head1: 0x7E 0x00

Types: 0x08

Lens: 0x01

Address: 0x00D9

Datas: 0x50

CRC: CRC_CCITT check value

Output: {Head2} {Types} {Lens} {Datas} {CRC}

1) Saved successful

PS: Head2: 0x02 0x00

Types: 0x00 (read succeed)

Lens: 0x01

Datas: 0x00

CRC: CRC_CCITT check value (0x33 0x31)

2) CRC failed

No response command

3) Unknown command response

No response command

2.1.5 Program Erasure Operation

Command Format:

Input: {Head1} {Types} {Lens} { NotUse } {Datas} {CRC}

PS: Head1: 0x7E 0x00 (2 bytes)

Types: 0x05 (1 byte)

Lens: 0x01 (1 byte) Numbers of Datas for Sequential read

NotUse: 0x0000 (2 bytes) , 2 bytes 0x00

Datas: 0x22 (1 bytes) , represents the data to be written; 0x22:erase the user program.

CRC: CRC_CCITT check value (2 bytes). Suitable for Types、Lens、NotUse、Ddatas;

Characteristic polynomial : $X^{16}+X^{12}+X^5+1$, multinomial coefficient: 0x1021, original value:0 ;

For single byte, the highest bit will be calculated at first, output will be without negation.

The reference code of C is as follows:

```

unsigned int crc_cal_by_bit(unsigned char* ptr, unsigned int len)
{
    unsigned int crc = 0;
    while(len-- != 0)
    {
        for(unsigned char i = 0x80; i != 0; i /= 2)
        {
            crc *= 2;
            if((crc&0x10000) != 0) //Last CRC * 2 , if the first one is 1, so divide 0x11021
                crc ^= 0x11021;
            if((*ptr&i) != 0) //If the standard is 1, so CRC = last CRC + standard CRC_CCITT
                crc ^= 0x1021;
        }
        ptr++;
    }
    return crc;
}
    
```

Note: users can fill 0xAB 0xCD at CRC byte when CRC validation is not required.

Output: {Head2} {Types} {Lens} {Datas} {CRC}

1) Erased successful

PS: Head2: 0x02 0x00

Types: 0x00 (read succeed)

Lens: 0x01

Datas: 0x00

CRC: CRC_CCITT check value (0x33 0x31)

2) CRC failed

No response command

3) Unknown command response

No response command

E.G.:

After erasure the user program, the device will automatically enter the boot program and wait for the download of the new user program

4) Erased successful

Input : 0x7E 0x00 0x05 0x01 0x00 0x00 0x22 xx xx

Output: 0x02 0x00 0x00 0x01 0x00 0x33 0x31

5) CRC wrong

Input: 0x7E 0x00 0x05 0x01 0x00 0x00 0x22 xx xx

Output: None

6) When length of command to short or more than 400ms after 0x7e 0x00, treat as unknown command.

Input: 0x7E 0x00 0x05 0x01 0x00 0x00 0x22

Output: None

2.1.6 List of zone bit

Zone Bit	0x0000
Data Bit	Function
Bit 7-2	Keep,Fixed to 110101b
Bit 1-0	01: Command Triggered Mode 10: Continuous Mode 11: Induction Mode
Zone Bit	0x0002
Data Bit	Function
Bit 7-1	Keep
Bit 0	Command mode triggers flags, Automatically reset after scanning 1: trigger 0: no trigger
Zone Bit	0x0003
Data Bit	Function
Bit 7-2	Keep
Bit 1	1: Close Settlement Code 0: Open
Bit0	1: Output content of settlement code 0: Not output
Zone Bit	0x0005
Data Bit	Function
Bit 7-0	Read interval 0x00: No interval 0x01-0xFF: 0.0-25.5s
Zone Bit	0x0006
Data Bit	Function
Bit 7-0	Time for single read 0x00: infinite 0x01-0xFF: 0.0-25.5s
Zone Bit	0x002B, 0x002A
Data Bit	Function
Bit 15	Keep
Bit 14-13	Parity Mode: 0: None 1: Odd 2: Even
Bit 12-0	0x09C4: Serial rate 1200 bps 0x0271: Serial rate 4800 bps 0x0139: Serial rate 9600 bps 0x00D0: Serial rate14400 bps 0x009C: Serial rate19200 bps 0x004E: Serial rate 38400 bps 0x0034: Serial rate 57600 bps 0x001A: Serial rate 115200bps E.G.: 9600 Baud rate: 0x002A = 0x39 , 0x002B = 0x01
Zone Bit	0x002C
Data Bit	Function
Bit 7-3	Keep, fixed to 01000b
	Bar code switch

Bit 2-1	00: forbid reading all bar code 01: all bar code can be read; 11: Default 10: Keep
Bit 0	Keep, fixed to 0b
Zone Bit	0x002E
Data Bit	Function
Bit 7-1	Keep, fixed to 0000110b
Bit0	Read EAN13 0: Forbid 1: Allow
Zone Bit	0x0033
Data Bit	Function
Bit 7-1	Keep
Bit0	Read Code128 0: Forbid 1: Allow
Zone Bit	0x0036
Data Bit	Function
Bit 7-1	Keep, fixed to 0000100b
Bit0	Read Code39 0: Forbid 1: Allow
Zone Bit	0x003F
Data Bit	Function
Bit 7-1	Keep
Bit0	Read QR 0: forbid 1: allow
Zone Bit	0x0060
Data Bit	Function
Bit 7	Serial/virtual serial output with or without protocol 0: Original data 1: With protocol
Bit6-5	Type of Tailed 00: CR(0x0D) 01: CRLF(0x0D,0x0A) 10: TAB(0x09) 11: None
Bit4	1: Allow add RF 0: forbid
Bit3	1: Allow add prefix 0: forbid
Bit2	1: Allow add Code ID 0: forbid
Bit1	1: Allow add suffix 0: forbid
Bit0	1: Allow add tail 0: forbid
Zone Bit	0x00B0
Data Bit	Function
Bit 7-2	Keep
Bit 1-0	Data Cut out settlement 00: Output whole data 01: Output Start part 10: Output End part 11: Output center part

Zone Bit	0x00B1
Data Bit	Function
Bit 7-0	Cut out M bytes from start 0x00-0xFF: 0-255 Byte
Zone Bit	0x00B2
Data Bit	Function
Bit 7-0	Cut out N bytes from end 0x00-0xFF: 0-255 Byte
Zone Bit	0x00D3
Data Bit	Function
Bit 7-3	Keep
Bit 2	Light control bit 0: Default light 1: Controllable light
Bit 1-0	Keep
Zone Bit	0x00D9 (Only read Zone bit)
Data Bit	Function
Bit 7-0	Function Zone bit 0x55: reset to defaults
Zone Bit	0x00E1 (Only read Zone bit)
Data Bit	Function
Bit 7-0	Hardware Version 0x64: V1.00 0x6E: V1.10 0x78: V1.20 0x82: V1.30 0x8C: V1.40
Zone Bit	0x00E2 (Only read Zone bit)
Data Bit	Function
Bit 7-0	Software Version 0x64: V1.00 0x6E: V1.10 0x78: V1.20 0x82: V1.30 0x8C: V1.40
Zone Bit	0x00E3 (Only read Zone bit)
Data Bit	Function
Bit 7-0	Year of software (Add 2000) 0x12: 2018 0x13: 2019 0x14: 2020
Zone Bit	0x00E4 (Only read Zone bit)

Data Bit	Function
Bit 7-0	Software month
	0x09: 9
	0x0A: 10
	0x0B: 11

Zone Bit	0x00E5 (Only read Zone bit)
Data Bit	Function
Bit 7-0	Software date
	0x09: 9
	0x0A: 10
	0x0B: 11

2.2 Setup Code

Customer can set module by scan setup code.

Note: the entire list of current zone bit is saved to Flash while the configuration is modified through the setup code, that is, the configuration that is configured through the serial port but not saved will also be saved together.



Default: setup code on

Output details in setup code:



Default: Not output



Off



Output

2.3 Reset

Back to Factory Setting by scan follow code.



Reset

3 Communication interface

GM61 can receive database, control module and set functional parameter by TTL - 232.

3.1 Serial Communication Interface

It's default and common to connect module and mainframe(such as PC, POS) by serial communication interface. Make sure communication parameter for module and mainframe are same, then it will communicate smooth and correctly.



Serial Output

TTL-232 is used for serial interface which suitable for most system. Required change-over circuit for RS-232.

Default Parameter as Form 3-1. Only Baud Rate can be changed.

Form 3-1 Default Parameters

Parameters	Default
Serial communication interface	Standard TTL-232
Baud rate	9600
Verification	N
Data bit	8
Stop bit	1
CTSRTS	N

Baud Rate Settlement



1200bps



4800bps



***9600bps**



14400bps



19200bps



38400bps



57600bps



115200bps

3.1.1 Serial Port Check Bit Configuration

Modify the parity bit of the serial port by scanning the following configuration code.



*NONE



ODD



EVEN

4 Read Mode

4.1 Continuous Mode

On this mode, reading module read code continuous and automatic.

Break after reading one code, break time is changeable.

Click the toggle key to pause. Then click to continuous cyclic read code.



***Continuous Mode**

Time settlement for single read

The longest time before first successful reading. After this time, module will be into no read time.

Single Read time: 0.1~25.5 s, step-size: 0.1s;

0 means infinite time.

Default time: 10s.



1000ms



3000ms



5000ms



***10000ms**



Infinite

Break time settlement

Time between two read. Can be settled from 0 to 25.5 s, step-size: 0.1s; default No Break.



***No break**



500ms



1000ms



1500ms



2000ms

Same barcode reading delay

The same barcode reading delay refers to that after the module reads the same bar code, it will be compared with the last reading time,when the interval is longer than the reading delay, the same barcode is allowed to be read, otherwise the output is not allowed.



Same barcode reading delay



*Same bar code reading without delay

Same barcode reading delay time

When the same barcode reading delay is enabled,scan the following code to set same barcode reading delay time.



*Infinite delay



500ms



1000ms



3000ms



5000m

4.2 Induction Mode

After setting, module begins to monitor brightness immediately. When scene changed, module will begin to read until time of image stabilization over.

After first successful reading or single reading time out, module will monitor brightness again after some time (changeable)

Module will cycle working as above when follow happen: module can't find code between single read time, then it will stop reading and jump to monitor brightness.

On induction mode, module can begin reading code by click, and it will begin to monitor brightness when release toggle key or successfully output information.



Induction Mode

Time settlement for single read

The longest time read before first successful reading. After this time, module will be into no read time.

Single Read time: 0.1~25.5 s, step-size: 0.1s;

0 means infinite time interval.

Default time: 10s.



1000ms



3000ms



5000ms



***10000ms**



infinite time interval

Break time settlement

After one successful output or time out for single read. Module will be into monitor after some time.

Time from 0 to 25.5 s, step-size: 0.1s; default No Break.



***No Break**



500ms



***1000ms**



1500ms



2000ms

Image stabilization time

Image stabilization time: the time cost after module find scene change then waiting for the scene stable. Time from 0s to 25.5s, step size 0.1s. Default 0s.



*0ms



100ms



400ms



1000ms



2000ms

Sensitivity

Detect the degree of change in the scene in inductive reading mode. When the reading module judges that the scene change degree meets the requirements, it will switch from the monitoring state to the reading state.



*Ordinary sensitivity



Low sensitivity



High sensitivity



Extra high sensitivity

4.3 Command Triggered Mode

Module begins to read when receive scan command from mainframe(bit0 of zone bit 0x0002 writes "1"), and stop at output or read timeout.



Command triggered mode

Under command triggered mode, command for serial port trigger is 7E 00 08 01 00 02 01 AB CD;

After receiving command, model will output " 02 00 00 01 00 33 31" and start scan.

Time settlement for single read

The longest time before first successful reading. After this time, module will be into no read time.

Single Read time: 0.1~25.5 s, step-size: 0.1s;

0 means infinite time.

Default time: Infinite.



1000ms



3000ms



5000ms



10000ms



***Infinite**

5 Lighting and Prompt

There are two modes to select by scanning different setting codes. Controllable light mode is completely controlled by the customer to send instructions to control the light, not affected by the reading mode.



***Default Light**



Controllable Light

Default light: the blue light is always on after the start of reading code, the blue light is off after the success of reading, and the green light is on (300ms), and then all lights are off.

Controllable light (the lighting control command cannot be saved and needs to be re-sent when the power is off) : Customers can configure different lighting modes according to their requirements. The specific controls are as follows:

·**Function Instruction:** lighting control command are mainly divided into two categories: general indicator light and colorful programming breathing lamp.

·**Input parameters:** function code, start color, end color, loop times.

Command (or instruction) package format:(General indicator light)

Header	Package identifier	Package length	Address	Function Code	Start Color	End Color	Times	CRC Check
2 bytes	1 byte	1bytes	2 byte	1 byte	1bytes	1bytes	1bytes	2 bytes
7E00H	0EH	04H	0000H	xx	xx	xx	xx	xxxx

·**Instruction:**

Function Code:LED mode control bit. 1- normal breathing light, 2- flashing light, 3- Normally on, 4- Normally off, 5- Gradually on,6- Gradually off, other function codes are not applicable to this command package format;

Starting color: When set to normal breathing light, the color from off to on is limited to the function of normal breathing light (function code 01). For other functions, the color should be consistent with the ending color.

Bit 0 is the blue light control bit; Bit1 is the green light control bit; Bit2 is the red light control bit. Set 1: light on, Set 0: light off.

For example, 0x01_ blue light on, 0x02_ green light on, 0x04_ red light on, 0x00_ All off ; Three colors can only be lit independently, can not mixed. If multiple colors are set, they will be lit according to the color priority. Blue >Green>Red.

Ending color: When set to normal breathing light, the color from on to off is limited to the function of normal breathing light (function code 01). For other functions, the color should be consistent with the starting color. The setting mode is the same as the starting color;

Loop times: Represents the number of breathing or flashing. When it's set to 0, it's an infinite loop; When set to other values, represents a limited number of breathing. The number of cycles is applicable to breathing and flashing functions. Other functions are invalid, such as normally open, normally closed, gradually open and gradually closed;

Colorful programming breathing lamp Command (or instruction) package format

Header	Package identifier	Package length	Address	Function code	Time Bit	Color Code 1	Color Code 2	Color Code 3	Color Code 4	Color Code 5	Loop times	CRC Check
2 bytes	1 byte	1 bytes	2 byte	1 byte	1 byte	1byte	1byte	1byte	1byte	1byte	1byte	2 bytes
7E00H	0DH	08H	0000H	07H	xx	xx	xx	xx	xx	xx	xx	xxxx

Auxiliary instructions:

Function code: 7-colorful programmed breathing light, other function codes are not applicable to this instruction package format;

Time Bit: Control the single breath of light, that is, the time from off to on, to off again.

The time range of a single breath is about 0.1s~10.0s, represented by a number between 1 and 100, and the number beyond this range is invalid.

That is, the time bit is set as 1 corresponding to 0.1s, and the time bit is set as 100 corresponding to 10.0s. The recommended time bit is set to 36, and the breathing time is the same as the normal breathing light (function code 0x01), which is about 3.6s.

Color code: composed of 5 bytes, as shown in the following table, each byte's color code is divided into two units, and each unit has 4 bits, starting from the high bit is divided into 1 effective bit, and 3 color control bits. Each unit controls the process by which lights of a certain color go from off to on to off.

In addition, the programmed breath light is lit in a one-cycle sequence starting with unit 1 of color 1, then unit 2 of color 1, then unit 1 of color 2, and so on.

Color control bit diagram table

Color (1byte)							
Unit 1				Unit 2			
Effecti ve bit	Red light bit	Green light bit	Blue light bit	Effecti ve bit	Red light bit	Green light bit	Blue light bit

Bit7	Bit6	Bit5	Bit4	Bit3	Bit2	Bit1	Bit0
------	------	------	------	------	------	------	------

Effective bit: 0- This unit and all units after this unit are invalid, 1- This unit is valid;

Red bit: 0- red light off, 1- red light on;

Green bit: 0- green off, 1- green on;

Blue bit: 0-blue light off, 1-blue light on;

If multiple colors are set, they will be lit according to the color priority. Blue >Green>Red.

Loop times: Represents the number of breath lighting. When set to 0, it represents an infinite loop, and when set to some other value, it represents a limited number of breathing.

Acknowledge package format:

Header	Type	Package identifier	Data	CRC Check
2 bytes	1 byte	1 bytes	1 byte	2 bytes
0200H	07H	01H	00H	xxxx

Note: Type =00H : command succeeds

Type =01H : command fail

6 Data Edition

Sometimes we need to edit the data before output to make data separation and processing more easily.

Data edition include:

- Add Prefix
- Add Suffix
- Cut data
- Output CodeID
- Output “RF” when fail to decode
- Add End words”Tail”

Output sequence after data edition:

【Prefix】 【CodeID】 【Data】 【Suffix】 【Tail】

6.1 Prefix

Add prefix

Prefix is on the head of encoding Information , and can be self-defined.

Scan the code to add prefix.



Allow to add prefix



***no prefix**

Change prefix

Scan “change prefix” and “setup code” code to change prefix.

Use 2 base 16 to express each character.

Max 15 characters.

ASCII on appendix D.



change prefix

E.G. Change prefix to “DATA”

1. “DTAT” in base 16: “44”, “41”, “54”, “41”
2. Confirm open the “ setup code”.(find on 2.2)
3. Scan “change prefix” code
4. Successively scan “Code ID”: “4”, “4”, “4”, “1”, “5”, “4”, “4”, “1”
5. Scan “save” code

6.2 Suffix

Add Suffix

Suffix on the end of encoding Information, and can be self-defined.



Allow add suffix



***no suffix**

Change suffix

Scan “ change suffix” and “setup code” code to change prefix.

Use base 16 to express each character.

Max 15 characters. ASCII on appendix D.



Change Suffix

E.G.: Change suffix to “DATA”

1. “DTAT” in base 16: “44”, “41”, “54”, “41”
2. Confirm opening the “setup code”.(find on 2.2)

3. Scan “change suffix” code
4. Successively scan “Code ID”: “4”, “4”, “4”, “1”, “5”, “4”, “4”, “1”
5. Scan “save” code

6.3 CODE ID

Add CODE ID

Users can identify different types of bar code by CODE ID. CODE ID use one character to identify and can be self- defined.



Allow add CODE ID



***close CODE ID**

Default of CODE ID

Scan “ Default of CODE ID” to back default ID, default ID on appendix C



all bar code back to default ID

Change CODE ID

Users can change CODE ID of any bar code by scan the setup code (as follow) and data edition code.

Base 16 is used to express each CODE ID.

ASCII on appendix D.

E.G.: change CODE ID of CODE 128 to “A”

1. Find “A”=“41” in base 16
2. Confirm opening the “setup code”.(find on 2.2)
3. Scan “ change CODE 128”
4. Successively scan “Code ID”: “4”, “1”
5. Scan “save” code

Change CODE ID LIST

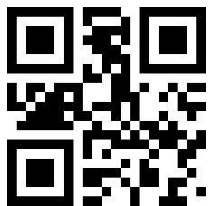

Change CODE ID of CODE 39



Change CODE ID of CODE 128



Change CODE ID of QR CODE

6.4 Tail

Open this function to help system quickly distinguish current decoding results.

Scan "Add tail" to open this function, if read success, there will be tail on the end of decode data.



Close tail



*Add tail "CR"



Add tail "TAB"



Add tail "CRLF"

6.5 Cut out Data

Open to output part of data.

[Data] is composed of [Start] + [Center] + [End]

Character length of "start" and "end" can be changed



*Output whole data



Output Start part



Output End Part



Output Center part

Change length of [Start]-M

Scan “ Change M” code and “data edition” code to change length of [Start], max 255 characters
Base 16 is used to express length. ASCII on appendix D.



Change M

Change length of [End]-N

Scan “ Change N” code and “data edition” code to change length of [Start], max 255 characters
Base 16 is used to express length. ASCII on appendix D.



Change N

Output Start part

E.G. Output “1234567890123” of whole decode information “ 1234567890123ABC”

1. “13” =”0D” in base 16
2. Confirm opening the “setup code”(find on 2.2)
3. Scan” change length M”
4. Successively scan “Code ID”: “0”, “D”
5. Scan “save” code
6. Scan” Output Start part”

Output End Part

E.G. Output “ABC” of whole decode information “ 1234567890123ABC”

1. “3” = “03” in base 16
2. Confirm opening the “setup code” (find on 2.2)
3. Scan ”change length N”
4. Successively scan “Code ID”.:”0”, “3”

5. Scan “save” code
6. Scan” Output End part”

Output Center part

E.G.: Output “0123” of whole decode information “ 1234567890123ABC”

1. “ 10” =”0A”; “3”=”03” in base16
2. Confirm opening the “setup code” (find on 2.2)
3. Scan “change length N”
4. Successively scan “Code ID”:”0”, “3”
5. Scan “save” code
6. Scan ” change length M”
7. Successively scan :Code ID”: “0”, “A”
8. Scan “save” code
9. Scan “Output Center part”

6.6 RF Information

RF(Read Fail): Users can self- define output information when read fail.



Output RF information



Default not output

Change RF information

Scan”change RF information” and “data edition code” to change RF information.

Base 16 is used to express, max at 15 character. ASCII on appendix D.



Change RF information

E.G.: change RF to “FAIL”

1. Find “FAIL” in base-16: “46”, “41”, “49”, “4C”
2. Confirm opening the “setup code”(find on 2.2)
3. Scan “ change RF information”

4. Successively scan “4” 、 “6” 、 “4” 、 “1” 、 “4” 、 “9” 、 “4” 、 “C”
5. Scan “save” code

6.7 Output Protocol

The output format of the decoded result can be modified in serial/virtual serial mode by scanning the following Settings code.



***Pure data**

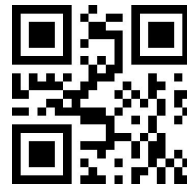

With the agreement

The format output with protocol is as follows, which can be configured by setting code

1. The format is as follows: <03>< length >< decoded data >
2. The format is as follows: <04>< length >< decoded data >< Tail ><CRC check >.The length represents the length of the decoded data and the tail, and CRC verifies all previous data.



Open <03> initiation protocol



***Open <04> initiation protocol**

7 Bar code type enables/disable configuration

7.1 All types of bar code can be decoded

After scan “ Forbid read all bar code” , module will only support to scan setup code.



Support all



Forbid read all bar code



*Open default support types

7.2 EAN-13



*Allow reading EAN-13



Forbid reading EAN-13

7.3 Code128



*Allow reading Code128



Forbid reading Code128

7.4 Code39



*Allow reading Code39



Forbid reading Code39

7.5 QR



*Allow reading QR



Forbid reading QR

8 Appendix A: Default Setting Table

Parameter	Default Setting	Note
Communication interface	Serial Output	
Read Mode	Continuous Mode	
All types of bar code can be decoded	Off	EAN-13 Code128 Code39 QR

9 Appendix B: Common serial port instruction

Function	Instruction
Baud rate 57600	7E 00 08 02 00 2A 34 00 C1 97
Save Settings to internal Flash	7E 00 09 01 00 00 00 DE C8
Check Baud rate	7E 00 07 01 00 2A 02 D8 0F
OPen Setup Code	7E 00 08 01 00 03 00 AB CD
Close Setup Code	7E 00 08 01 00 03 02 AB CD

10 Appendix C: Code ID

Type of Bar Code	Corresponding character	Zone bit address
Code 128	j	0x96
Code 39	b	0x97
QR Code	Q	0xA2

11 Appendix D: ASCII

Hexadecimal	Decimalism	Character
00	0	NUL
01	1	SOH
02	2	STX
03	3	ETX
04	4	EOT
05	5	ENQ
06	6	ACK
07	7	BEL
08	8	BS
09	9	HT
0a	10	LF
0b	11	VT
0c	12	FF
0d	13	CR
0e	14	SO
0f	15	SI
10	16	DLE
11	17	DC1
12	18	DC2
13	19	DC3
14	20	DC4
15	21	NAK
16	22	SYN
17	23	ETB
18	24	CAN
19	25	EM
1a	26	SUB
1b	27	ESC
1c	28	FS

Hexadecimal	Decimalism	Character
1d	29	GS
1e	30	RS
1f	31	US
20	32	SP
21	33	!
22	34	"
23	35	#
24	36	\$
25	37	%
26	38	&
27	39	`
28	40	(
29	41)
2a	42	*
2b	43	+
2c	44	,
2d	45	-
2e	46	.
2f	47	/
30	48	0
31	49	1
32	50	2
33	51	3
34	52	4
35	53	5
36	54	6
37	55	7
38	56	8
39	57	9
3a	58	:
3b	59	;
3c	60	<
3d	61	=
3e	62	>

Hexadecimal	Decimalism	Character
3f	63	?
40	64	@
41	65	A
42	66	B
43	67	C
44	68	D
45	69	E
46	70	F
47	71	G
48	72	H
49	73	I
4a	74	J
4b	75	K
4c	76	L
4d	77	M
4e	78	N
4f	79	O
50	80	P
51	81	Q
52	82	R
53	83	S
54	84	T
55	85	U
56	86	V
57	87	W
58	88	X
59	89	Y
5a	90	Z
5b	91	[
5c	92	\
5d	93]
5e	94	^
5f	95	_
60	96	'

Hexadecimal	Decimalism	Character
61	97	a
62	98	b
63	99	c
64	100	d
65	101	e
66	102	f
67	103	g
68	104	h
69	105	i
6a	106	j
6b	107	k
6c	108	l
6d	109	m
6e	110	n
6f	111	o
70	112	p
71	113	q
72	114	r
73	115	s
74	116	t
75	117	u
76	118	v
77	119	w
78	120	x
79	121	y
7a	122	z
7b	123	{
7c	124	
7d	125	}
7e	126	~
7f	127	DEL

12 Appendix E: Data code

0~9



0



1



2



3



4



5



6



7



8



9

A-F



A



B



C



D



E



F

13 Appendix F: Save or Cancel

After reading the data code, you need to scan the "save" setting code to save the data which you read. If there is an error when reading the data code, you can cancel the error reading.

For example, read a set code, and read data "A", "B", "C" and "D" in turn.

If you read "cancel the last read bit", the last read digit "D" will be cancelled.

If you read "cancel the previous read a string of data" will cancel the read data "ABCD",

If you read "cancel modification Settings", you will cancel the data "ABCD" and exit the modification Settings.



Save



Cancel the last read bit



Cancel the previous read a string of data



Cancel modification settings