

## LI10768T080IA3098

8.0 inch, 1024\*768 pixels resolution, LVDS interface, IPS-TFT-LCD



## Table of Contents

1 General Feature.....	3
2 Mechanical Drawing.....	4
3 Input/Output Terminals.....	5
4 Electrical Characteristics.....	7
5 Timing Characteristics .....	8
6 Optical Characteristics.....	11
7 Environmental Reliability Test .....	14
8 Packing Capacity & Dimension .....	15
9 Appearance Inspection .....	16
10 Precautions for Use of LCD Modules .....	19
11 LCD Introduction.....	20
12 Important Disclaimer.....	24

## 1 General Feature

Feature		Description	Unit
Display Spec.	Size	8.0	inch
	Resolution	1024(H)*768(V)	pixels
	Pixel Configuration	RGB stripe	-
	Pixel Pitch	0.05275(W)*0.15825(H)	mm
	Viewing Direction	ALL	-
Mechanical Characteristics	Outside Dimension	183.0(W)*141.0(H)*3.5(D)	mm
	Active Area	162.05(W)*121.54(H)	mm
	Luminance	300	cd/m <sup>2</sup>
	LED Numbers	27 LEDS	-
	Pin Order	From left to right 40PIN_0.5mm	-
	Weight	-	g
Electrical Characteristics	Interface	LVDS	-
	Color Depth	16.7M	colors
	Driver Condition	3.3(Type)	V
	Driver IC	HX8282-A11DPD300/HX8695-B01BP300	-
Temperature Range	Operating Temp.	-20~70	°C
	Storage Temp.	-30~80	°C

### Note: Requirements on Environmental Protection: RoHS

You can use dynamic screen saver wallpapers to avoid afterimages caused by fixed paper display for a long time

## 2 Mechanical Drawing

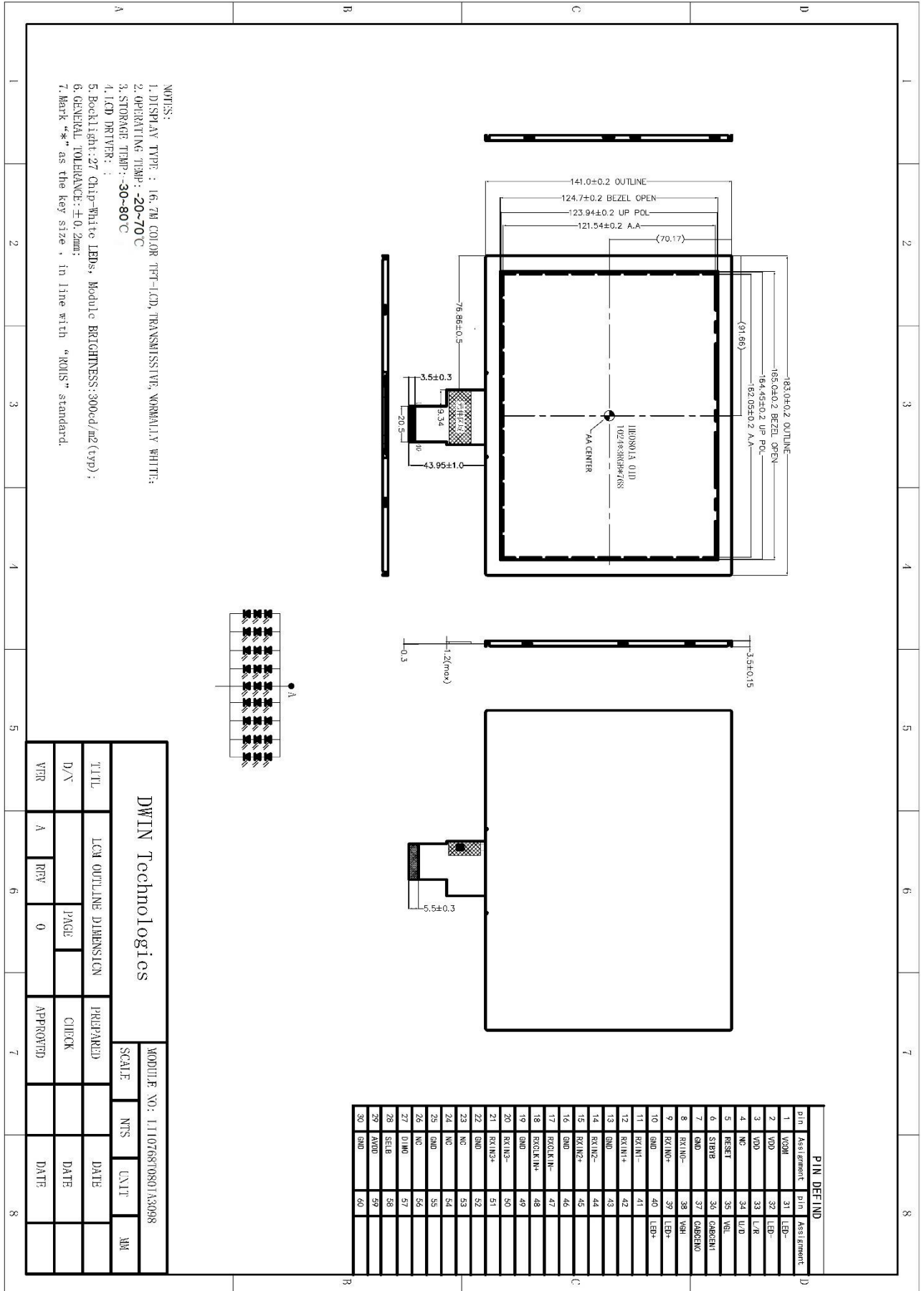

DWIN Technologies				MODULE NO: LI10768T080IA3098	
				SCALE	MKS
TITLE	LCM OUTLINE DIMENSION	PREPARED	CHECK	DATE	
D/V		PAGE		DATE	
VER	A	REV	0	APPROVED	DATE

### 3 Input/Output Terminals

Pin NO.	Symbol	Function	Remark
1	VCOM	Common Voltage	
2	VDD	Power Voltage for digital circuit	
3	VDD	Power Voltage for digital circuit	
4	NC	No connection	
5	RESET	Global reset pin	
6	STBYB	Standby mode, Normally pulled high STBYB= "1", normal operation STBYB = "0", timing controller, source driver will turn off, all output are High-Z	
7	GND	Ground	
8	RXIN0-	- LVDS differential data input	
9	RXIN0+	+ LVDS differential data input	
10	GND	Ground	
11	RXIN1-	- LVDS differential data input	
12	RXIN1+	+ LVDS differential data input	
13	GND	Ground	
14	RXIN2-	- LVDS differential data input	
15	RXIN2+	+ LVDS differential data input	
16	GND	Ground	
17	RXCLKIN-	- LVDS differential clock input	
18	RXCLKIN+	+ LVDS differential clock input	
19	GND	Ground	
20	RXIN3-	- LVDS differential data input	
21	RXIN3+	+ LVDS differential data input	
22	GND	Ground	
23	NC	No connection	
24	NC	No connection	
25	GND	Ground	
26	NC	No connection	
27	DIMO	Backlight CABC controller signal output	
28	SELB	6bit/8bit mode select	
29	AVDD	Power for Analog Circuit	



30	GND	Ground	
31	LED-	LED Cathode	
32	LED-	LED Cathode	
33	L/R	Horizontal inversion	
34	U/D	Vertical inversion	
35	VGL	Gate OFF Voltage	
36	CABCEN1	CABC H/W enable	
37	CABCEN0	CABC H/W enable	
38	VGH	Gate ON Voltage	
39	LED+	LED Anode	
40	LED+	LED Anode	

DWIN Technology Technical Document

## 4 Electrical Characteristics

### 4.1 Driving TFT LCD Panel

Item	Symbol	Min.	Typ.	Max.	Unit	Remark
Power Voltage	$V_{CC}$	3.0	3.3	3.6	V	
	$AV_{DD}$	9.8	10	10.2	V	
	$V_{GH}$	18.6	18.9	19.2	V	
	$V_{GL}$	-8.1	-7.8	-7.5	V	
Input Logic High Voltage	$V_{IH}$	$0.7V_{CC}$	-	$V_{CC}$	V	
Input Logic Low Voltage	$V_{IL}$	0	-	$0.3V_{CC}$	V	
Input Signal Voltage	$V_{COM}$	2.6	3.6	4.6	V	

### 4.2 LED Backlight Specification

Item	Symbol	Min.	Typ.	Max.	Unit	Remark
Forward Voltage	$V_F$	8.4	9	10.2	V	
Luminance	$L_v$	-	300	-	cd/m <sup>2</sup>	
Uniformity(with L/G)	Avg	75	80	-	%	
LED Life-Time	Hr	-	30000	-	Hour	

Note: 27 LEDs (3LEDs Serial, 9ways Parallel)

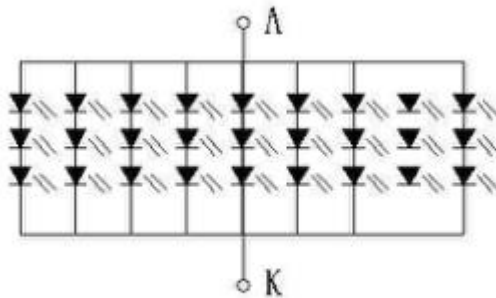

## 5 Timing Characteristics

### 5.1 HV Mode

Parameter	Symbol	Value			Unit
		Min.	Typ.	Max.	
Horizontal Display Area	thd	1024			DCLK
DLCK Frequency	Fclk	52	65	71	MHZ
HSD Period	Th	1114	1344	1400	DCLK
HSD Pulse Width	thpw	1	36	40	DCLK
HSD Back Porch	thbp	48			DCLK
HSD Front Porch	tfbp	12	118	512	DCLK
Vertical Display Area	tvd	768			H
VSD period	tv	778	806	845	H
VSD Pulse Width	Tvpw	1	4	20	H
VSD Back Porch	Tvbp	12			H
VSD Front Porch	tvfp	2	15	227	H

### 5.2 Mode DC Electrical Characteristics

Parameter	Symbol	Conditions	Specification			UNIT
			MIN	TYP	MAX	
Logic high level input voltage	V <sub>IHLPCD</sub>	LP-CD	450	-	1350	mV
Logic low level input voltage	V <sub>ILLPCD</sub>	LP-CD	0	-	200	mV
Logic high level input voltage	V <sub>IHLPRX</sub>	LP-RX (CLK, D0, D1)	880	-	1350	mV
Logic low level input voltage	V <sub>ILLPRX</sub>	LP-RX (CLK, D0, D1)	0	-	550	mV
Logic low level input voltage	V <sub>ILLPRXULP</sub>	LP-RX (CLK ULP mode)	0	-	300	mV
Logic high level output voltage	V <sub>OHLPTX</sub>	LP-TX (D0)	1.1	-	1.3	V
Logic low level output voltage	V <sub>OLLPTX</sub>	LP-TX (D0)	-50	-	50	mV
Logic high level input current	I <sub>IH</sub>	LP-CD, LP-RX	-	-	10	μA
Logic low level input current	I <sub>IL</sub>	LP-CD, LP-RX	-10	-	-	μA
Input pulse rejection	SGD	DSI-CLK+/-, DSI-Dn+/- (Note 3)	-	-	300	Vps



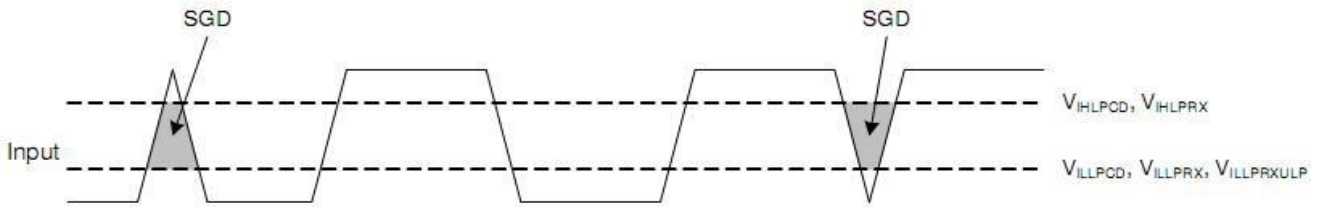

Spike/glitch rejection-DSI

## 5.3 AC Characteristics

(VSS=VSSI=DVSS=0V, VDDI=1.65V to 3.6V, VDD=2.5V to 3.6V, Ta = -30 to 70 °C)

Signal	Symbol	Parameter	MIN	TYP	MAX	Unit	Description
DSI-CLK+/-	2xUI <sub>INST</sub>	Double UI instantaneous	4	-	8	ns	4 Lane (Note 2)
			3	-	8	ns	3 Lane (Note 2)
			2.352	-	8	ns	2 Lane (Note 3)
DSI-CLK+/-	UI <sub>INSTA</sub> UI <sub>INSTB</sub>	UI instantaneous halves (UI = UI <sub>INSTA</sub> = UI <sub>INSTB</sub> )	2	-	4	ns	4 Lane (Note 2)
			1.5	-	4	ns	3 Lane (Note 2)
			1.176	-	4	ns	2 Lane (Note 3)
DSI-Dn+/-	t <sub>DS</sub>	Data to clock setup time	0.15xUI	-	-	ps	
DSI-Dn+/-	t <sub>DH</sub>	Data to clock hold time	0.15xUI	-	-	ps	
DSI-CLK+/-	t <sub>DRTCLK</sub>	Differential rise time for clock	150	-	0.3xUI	ps	
DSI-Dn+/-	t <sub>DRTDATA</sub>	Differential rise time for data	150	-	0.3xUI	ps	
DSI-CLK+/-	t <sub>DFTCLK</sub>	Differential fall time for clock	150	-	0.3xUI	ps	
DSI-Dn+/-	t <sub>DFTDATA</sub>	Differential fall time for data	150	-	0.3xUI	ps	

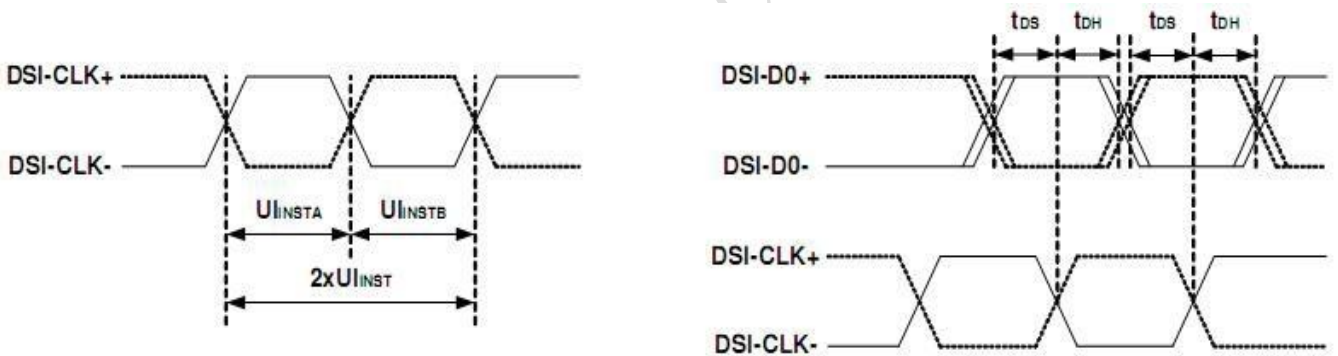

DSI clock channel timing

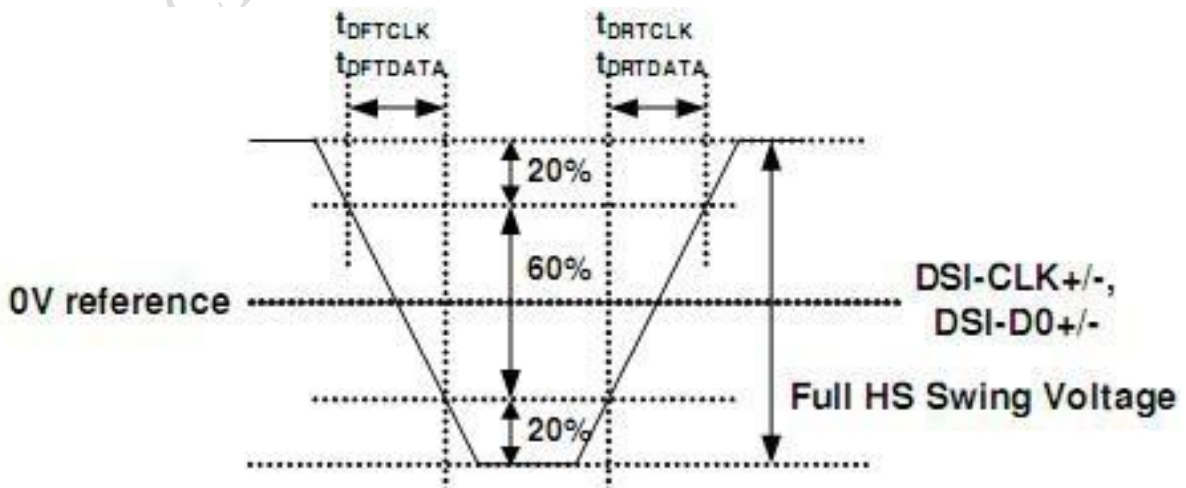

### Rising and fall time on clock and data channel

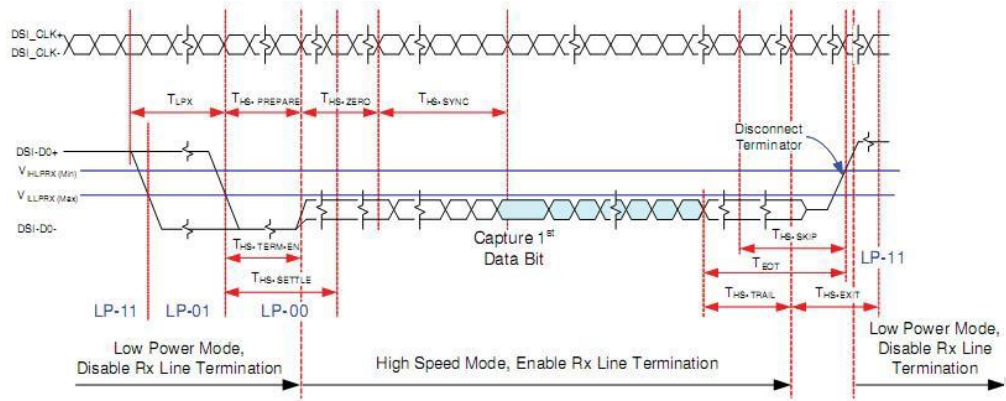

### 5.4 Clock Lanes-high Speed Mode To/From Low Power Mode Timing

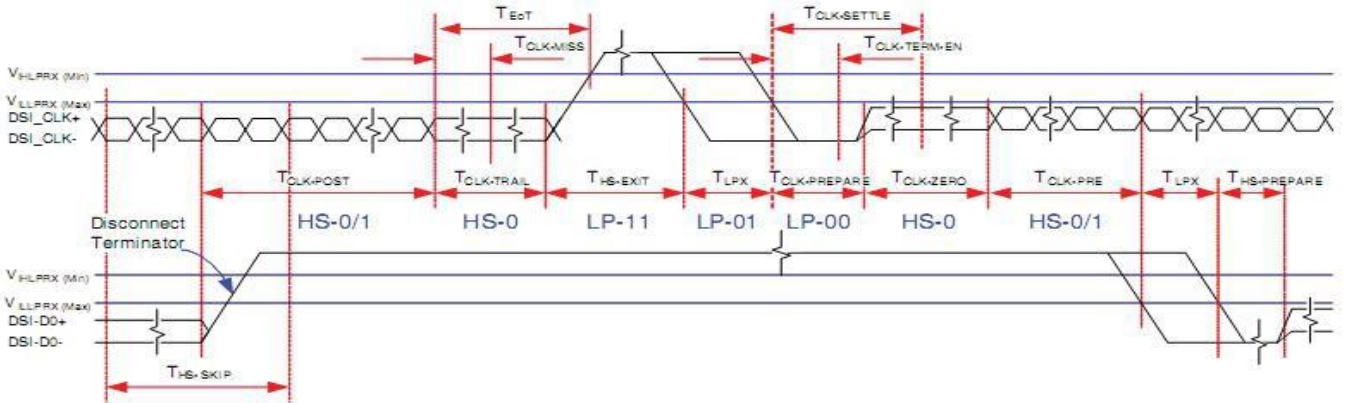

## 6 Optical Characteristics

Item	Symbol	Condition	Min.	Typ.	Max.	Unit	Remark
Viewing Angle	Top	$CR \geq 10$		85	-	Deg.	Note 2
	Bottom			85	-		
	Left			85	-		
	Right			85	-		
Contrast Ratio	CR	$\theta=0^\circ$	600	800	-		
Response Time	$T_r+T_f$	$\theta=0^\circ$	-	35	50	ms	
Color Chromaticity (CIE1931)	Wx	$\theta=0^\circ$	0.260	0.290	0.320		
	Wy		0.290	0.320	0.350		
	Rx		TBD	TBD	TBD		
	Ry		TBD	TBD	TBD		
	Gx		TBD	TBD	TBD		
	Gy		TBD	TBD	TBD		
	Bx		TBD	TBD	TBD		
	By		TBD	TBD	TBD		
Color Gamut	NTSC	$\theta=0^\circ$	-	55	-	%	

Test conditions:

IF= 180 mA, and the ambient temperature is 25°C.

**Note 1: Definition of optical measurement system.**

The optical characteristics should be measured in dark room. After 5 minutes operation, the optical properties are measured at the center point of LCD.

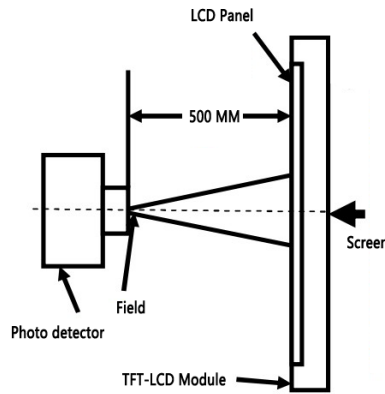

**Note 2: Definition of viewing angle range and measurement system.**

The viewing angle is measured at the center point of the LCD by BM-7A.

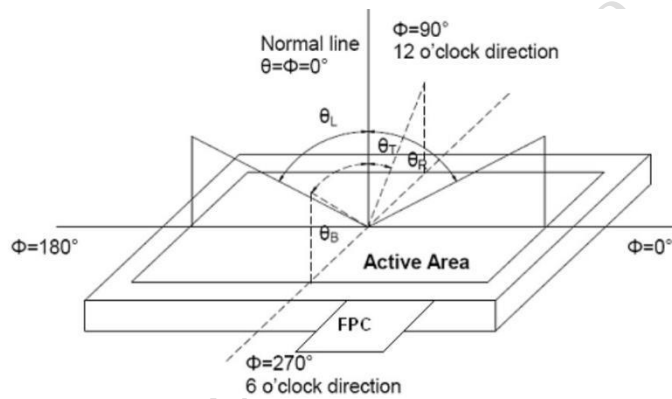

**Note 3:** When the radiation of the light source is exactly the same in the visible region and the absolute blackbody, the temperature of the blackbody is called the color temperature of the light source. Color temperature is an index to measure the degree of light source color (cold color, warm color).

Warm color < 3300K, intermediate color 3300 ~ 5000K, cold color > 5000K.

**Note 4: Definition of response time.**

The response time is defined as the LCD optical switching time interval between “White” state and “Black” state. Time ON (TON) is the time between photo detector output intensity changed from 90% to 10%. And time off (TOFF) is the time between photo detector output intensity changed from 10% to 90%.

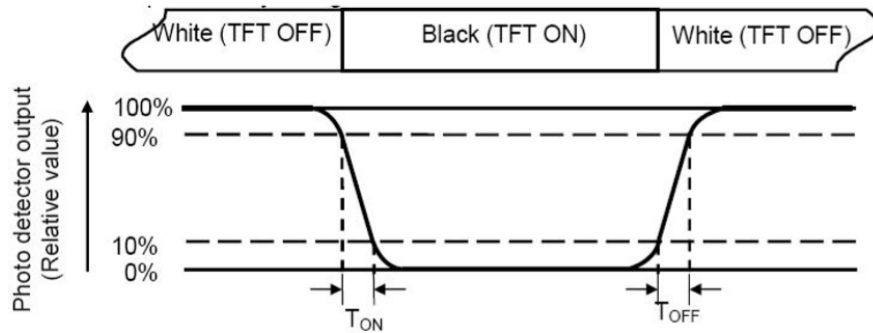

**Note 5: Definition of color chromaticity (CIE1931).**

Color coordinates measured at center point of LCD.

**Note 6: Definition of luminance.**

Measure the luminance of white state at center point.

## 7 Environmental Reliability Test

NO	Test Item	Condition	Remarks
1	High Temperature Operation	Ta=+70℃, 96hours	IEC60068-2-1:2007 GB2423.2-2008
2	Low Temperature Operation	Ta=-20℃, 96hours	IEC60068-2-1:2007 GB2423.1-2008
3	High Temperature Storage	Ta=+80℃, 96hours	IEC60068-2-1:2007 GB2423.2-2008
4	Low Temperature Storage	Ta=-30℃, 96hours	IEC60068-2-1:2007 GB2423.1-2008
5	Storage at High Temperature and Humidity	Ta=+50℃, 90% RH,96hours	IEC60068-2-78 :2001 GB/T2423.3-2006
6	Thermal Shock	-20℃/30min← →+60℃/30min, after 10cycle, Restore 2H at 25℃	Start with cold temperature, End with high temperature, IEC60068-2-14:1984, GB 2423.22-2002
7	ESD(non-operation)	150pF, 330Ω, Contact: ±4KV, Air: ±8KV Measure point: LCD glass and metal bezel	IEC61000-4-2:2001 GB/T 17626.2-2006
8	Vibration Test	10Hz~45Hz, 100m/s <sup>2</sup> , 120min	IEC60068-2-6:1982 GB/T 2423.10-1995
9	Shock Test	Half-sine wave,300m/s <sup>2</sup> ,11ms	IEC60068-2-27:1987 GB/T 2423.5-1995
10	Drop Test(package state)	800mm, concrete floor,1corner, 3edges, 6 sides each time	IEC60068-2-32:1990 GB/T 2423.8-1995

## 8 Packing Capacity & Dimension

Dimension			
Dimension(mm)	183.0(W)*141.0(H)*3.5(D)		
Net Weight	-		
Packing Capacity			
Size	LCD Size and Resolution	Layer	Quantity(Pcs)
250mm(L)x200mmx80mm(W)	8.0 inch 1024*768	1	1
600mm(L)x450mm(W)x300mm(H)	8.0 inch 1024*768	1	60

Packing instruction:

The LCD is placed in the grid, covered with a PE static bag and compactly assembled, the upper and the lower layers of the grid are protected by buffer spaces.

The LCD covered with a PE static bag and compactly assembled



placed in the grid



The upper and the lower layers of the grid are protected by buffer spaces



Packed



## 9 Appearance Inspection

### 9.1 General rules for inspection

9.1.1 Anti-static wearables (anti-static wristbands, gloves) must be worn during the inspection.

9.1.2 Do not use bare hands to touch the position of the device, golden fingers, and the surface of the screen to prevent the sweat from human hands from causing oxidation and affecting the appearance.

9.1.3 It is forbidden to stack products out of specification and handle them with care to avoid damage to components.

9.1.4 The repaired products need to be inspected to prevent rosin and tin slag from exceeding the specifications.

9.1.5 When technical documents and process documents have specific requirements for products, the technical documents and process documents shall be the main requirements.

### 9.2 Inspection conditions

9.2.1 The conditions of display function check

Angle:  $\pm 5^\circ$ ;

Inspection method: visual inspection. The inspection object is 30-40cm away from the light source, and the eye is 30-40cm away from the inspection object;

Illumination: 300-500Lux;

Inspection time: 5-10S.

9.2.2 Visual inspection conditions

Angle:  $\pm 45^\circ$ ;

Inspection method: visual inspection. The inspection object is 30-40cm away from the light source, and the eye is 30-40cm away from the inspection object;

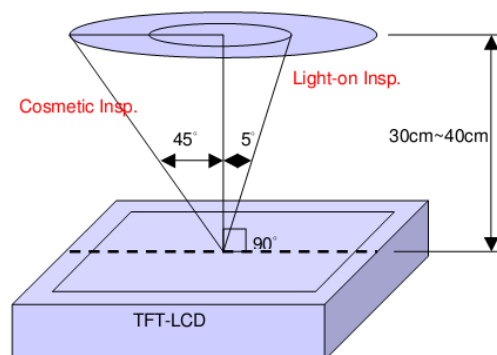

Illumination: 800-1500Lux;

Inspection time: 5-10S.



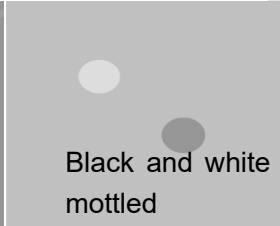

## 9.3 Inspection standards

Type	Test Items	Judgement Standard	Defect Category	
Display state	Dead pixels	No dead pixels		
	mura	From different angles, the brightness is required to be uniform. Under the 64-level grayscale or pure black interface, there should be no uneven display brightness within the viewing angle range of 45° through 6% ND FILTER. Y series (TV film) LCD screen does not have specific requirements, and the picture inspection does not affect the display as qualified. <div style="display: flex; justify-content: space-around; margin-top: 10px;">   </div>	Slight defect	
	Light leakage	Under the 64-level grayscale or pure black interface, there should be no obvious light leakage within the viewing angle range of 45° by visual inspection or through 6% ND FILTER. Y series (TV LCD screen) series can be without obvious visual defects.	Slight defect	
	Linear foreign bodies	1. $W \leq 0.05$ , $L \leq 2\text{mm}$ , negligible; 2. $0.05\text{mm} < W \leq 0.1\text{mm}$ , $L \leq 2\text{mm}$ , $N \leq 3$ ; 3. $W > 0.1\text{mm}$ , $L > 2\text{mm}$ , not allowed.	Slight defect	
Screen surface	Within the effective area Spotted: 1. $D \leq 0.2\text{mm}$ and it is not a piece, it is not counted; 2. $0.2\text{mm} < D \leq 0.5\text{mm}$ , $N \leq 3$ ; 3. $D > 0.5\text{mm}$ , $L > 0.5\text{mm}$ , $W > 0.5\text{mm}$ are not allowed; (The spotted foreign objects shall not exceed the point-line gauge $D=0.5$ , and the black dot coverage shall be checked, and the spotted foreign objects shall be judged within the range of $D=0.5$ )	Slight defect		
	Foreign objects Scratch Air bubbles	Linear: 1. $W \leq 0.05$ , $L \leq 2\text{mm}$ , ignored; 2. $0.05 < W \leq 0.1\text{mm}$ , $L \leq 2\text{mm}$ , $N \leq 3$ ; 3. $W > 0.1\text{mm}$ , $L > 2\text{mm}$ , not allowed.		
	Outside the effective area Foreign objects Scratches Air bubbles	Foreign objects are not checked, and bubbles are not allowed to $D > 1\text{mm}$ ; Non-inductive scratches of no more than $0.1 \times 8\text{mm}$ are allowed.	Slight defect	
	Crack	Not allowed.		Slight defect

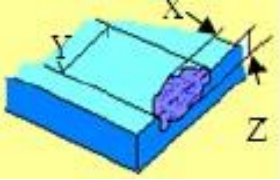
	Notch	<ol style="list-style-type: none"> <li>Does not affect the appearance from the front;</li> <li>Does not affect the relevant alignment;</li> <li><math>X \leq 1\text{mm}</math>, <math>Y \leq 1\text{mm}</math>, <math>N \leq 2</math>.</li> </ol>		Slight defect
	Glass side Foreign objects Dirty	<ol style="list-style-type: none"> <li>The foreign body on the side is not controlled;</li> <li>The paint pen marks on the side are not controlled;</li> <li>Side oily note printing is not allowed.</li> </ol>		Slight defect
FPC	Cracks Goldfinger crease	Not allowed.		Heavy deficit
	Crease	Slight creases are not controlled; The crease is whitish and has lines, which is not allowed.		Heavy deficit
	Top wound, stab wound	No damage to the line, $D \leq 0.2\text{mm}$ ; Damage to the line is not allowed.		Heavy deficit
	Scratch	Slight scratches on the surface are not controlled; Damage to the line is not allowed.		Heavy deficit
	Goldfinger scratch	$W \leq 0.05\text{mm}$ , no control; $W > 0.05\text{mm}$ , not allowed; Test probe tip marks are not controlled.		Heavy deficit
	Component	Under-soldering, over-soldering and false soldering are not allowed.		Heavy deficit

## 10 Precautions for Use of LCD Modules

### 10.1 Handling Precautions

10.1.1 The display panel is made of glass. Do not subject it to a mechanical shock by dropping it from a high place, etc.

10.1.2 If the display panel is damaged and the liquid crystal substance inside it leaks out, be sure not to get any in your mouth, if the substance comes into contact with your skin or clothes, promptly wash it off using soap and water.

10.1.3 Do not apply excessive force to the display surface or the adjoining areas since this may cause the color tone to vary.

10.1.4 The polarizer covering the display surface of the LCD module is soft and easily scratched. Handle this polarizer carefully.

10.1.5 If the display surface is contaminated, breathe on the surface and gently wipe it with a soft dry cloth. If still not completely clear, Can only use LCD dedicated cleaner, the following organic solvent can not be used:

- Isopropyl alcohol
- Ethyl alcohol
- Ketone
- Aromatic solvents

10.1.6 Do not attempt to disassemble the LCD Module.

10.1.7 If the logic circuit power is off, do not apply the input signals.

10.1.8 To prevent destruction of the elements by static electricity, be careful to maintain an

10.1.9 optimum work environment.

10.1.9.1 Be sure to ground the body when handling the LCD Modules.

10.1.9.2 Tools required for assembly, such as soldering irons, must be properly ground.

10.1.9.3 To reduce the amount of static electricity generated, do not conduct assembly and other work under dry conditions.

10.1.9.4 The LCD Module is coated with a film to protect the display surface. Be care when peeling off this protective film since static electricity may be generated.

### 10.2 Storage precautions

10.2.1 When storing the LCD modules, avoid exposure to direct sunlight or to the light of fluorescent lamps.

10.2.2 The LCD modules should be stored under the storage temperature range. If the LCD modules will be stored for a long time, the recommend condition is:

Temperature: 0°C ~ 40°C Relatively humidity: ≤80%.

10.2.3 The LCD modules should be stored in the room without acid, alkali and harmful gas.

### 10.3 Transportation Precautions

10.3.1 The LCD modules should be no falling and violent shocking during transportation, and also should avoid excessive press, water, damp and sunshine.

## 11 LCD Introduction

### 11.1 Process capacity

DWIN adopts original class A glass and the entire production is in the park from cleaning, cutting, bonding, and laminating of large glass to backlight assembly, quality inspection, and aging.

There are 12,000 square meters of clean workshop, with a monthly production capacity of about 2.5 million pieces. Each piece of LCD produced in the factory is for 30 days of aging.



### 11.2 ODM service

Based on LCD products of 1.5~21.5 inches, DWIN provides the following customization services.

1、LCD HDMI interface customization.

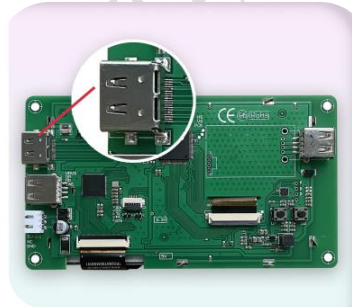

HDMI interface

2、Special screen customization such as high brightness, ultra-wide temperature and strong electromagnetic protection.

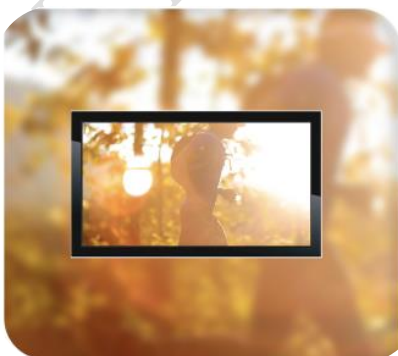

High brightness  
(up to 1200nit)



Ultra-wide temperature  
(-40~85°C)



Strong electromagnetic  
protection

### 3、Lamination customization service of LCD + TP.



LCM+RTP



LCM+CTP

### 4、Customization service of DWIN self-developed T5L ASIC+ LCD + TP.



T5L ASIC

### 5、Smart screen finished product customization.

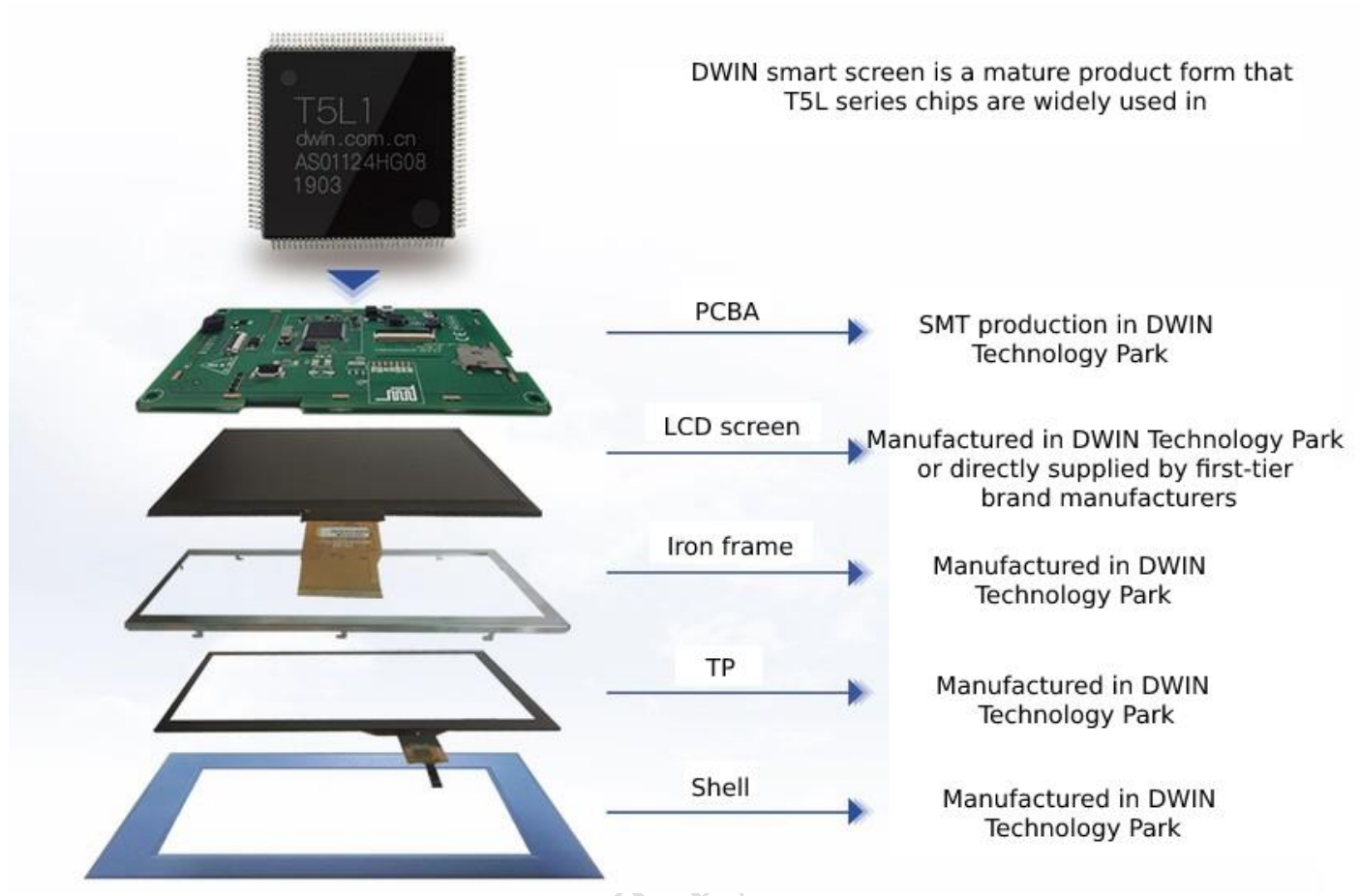

Please contact our sales staff for other customization needs.

## Record of Revision

Rev	Date	Description	Editor
00	2022-04-24	First Release	Ouyang Kaixing
01	2022-12-13	Add Product Picture and Update Operating/Storage Temperature	Chen Xian
02	2022-12-14	Add Driver IC	Chen Xian
03	2023-02-22	Update Packing Capacity	Chen Xian
04	2024-03-29	Add Important Disclaimer	Chen

Please contact us if you have any questions about the use of this document or our products, or if you would like to know the latest information about our products:

Customer service tel: +86 400 018 9008

Customer service email: [dwinhmi@dwin.com.cn](mailto:dwinhmi@dwin.com.cn)

DWIN Developer forum: <https://forums.dwin-global.com/index.php/forums/>

Thank you all for continuous support of DWIN, and your approval is the driving force of our progress!

## Important Disclaimer

DWIN reserves the right to make any changes to product designs without prior notice.

Customers should ensure strictly adhering to all the relevant standards and requirements during the product application process, including but not limited to functional safety, information security, and regulatory provisions.

DWIN shall not bear any joint and several liability for any consequences that may arise from customers' adoption of DWIN products. In particular, for risks that may lead to significant property losses, environmental hazards, personal injury, or even death, especially in high-risk application areas such as military applications, flammable and explosive places, and life-saving medical equipment, customers should independently assess the risks and take corresponding preventive and protective measures. DWIN shall not bear any relevant responsibility.