

1W & Industrail

Mesh NetWork & AES128 Encryption

Transparent Data Transmission

Product Specification



Catalog

1. Overview	- 2 -
2. Feature	- 3 -
3. Application	- 3 -
4. Block Diagram	- 4 -
5. Electrical Characteristics	- 4 -
6. Operation	- 5 -
1) Power on Reset	- 5 -
2) Working Mode	- 5 -
3) Non MESH Data transmission mode	- 6 -
4) MESH network transmission mode	- 7 -
5) AES128 data encryption transmission mode	- 8 -
6) LBT Features (Listen Before Talk)	- 8 -
7) Dormancy	- 8 -
7. Data transfer overview	- 9 -
8. Setting mode	- 10 -
9. Pin definition	- 18 -
10. Typical Application circuit	- 19 -
11. Accessories	- 19 -
12. Mechanical dimension(Unit: mm)	- 21 -
13. Order information	- 21 -
14. FAQ	- 22 -

Note: Revision History

Revision	Date	Comment
V1.0	2018-2	First release
V2.0	2018-9-27	Upgrade LBT, RSSI, node & route sharing, random delay, etc.
V3.0	2018-11-27	LBT function upgrade
V3.1	2018-12-20	Description update
V3.2	2019-5-28	Description of RSSI ,LBT updated
V3.3	2020-3	Update CS PIN description
V3.4	2021-7	Wireless transmission rate setting range on page 13: 1932 changed to 2932
V3.5	2022-9	Correct some content
V4.0	2022-10	ADD: Mesh hop level , CRC encryption optional

1. Overview

LoRa Pro module is a new series of upgraded networking wireless communication modules from Wireless. It is based on Semtech's SX127X chip and uses advanced LoRa spread spectrum modulation frequency hopping technology to achieve high sensitivity. The penetrating power and communication distance are far superior to the current FSK and GFSK products, and have stronger anti-interference. In order to meet the application needs of different customers, we design the module software of this series as an all-in-one way. Users can switch between different working modes through the PC software configuration module. In MESH mode, the routing module has automatic routing. Function, the user can form a network transmission without blind zone without distance limitation by means of multi-module combination. At the same time, users can also encrypt AES128 wireless data through PC software or serial port instructions, making data transmission more secure.

LoRa6100Pro module is designed for 1w output power and is available in TTL/RS232 /RS485 levels. It is widely used in wireless remote transmission control.

LoRa6100Pro strictly uses lead-free process for production and testing, and meets RoHS and Reach standards.

Note: The LoRa Pro series can be configured to be compatible with our previous LoRa data transmission modules.

2. Feature

- AES128 data encryption method
- No blind zone without distance limitation
- Single module open transmission distance of 8Km @ low rate
- Frequency band: 433/470/868/915 MHz for option
- Up to 40 channels every Band
- Diversified serial port parameters
- Operating voltage range: 3.3 ~ 6.5 V
- LBT (Listen Before Talk) function optional
- Node/route/node+route optional in MESH mode (Hop level in MESH mode)
- CRC encryption optional
- Built-in hardware reset protection circuit
- LoRa modulation
- TTL interface
- Sensitivity up to -139 dBm
- Maximum output power: 500 mW/1W (+30/+27 dBm)
- Operating temperature range: -40 ~ +85 °C

3. Application

- Remote control
- Remote meter reading
- Industrial data collection
- Home automation telemetry

- Wireless data communication
- Access control system

4. Block Diagram

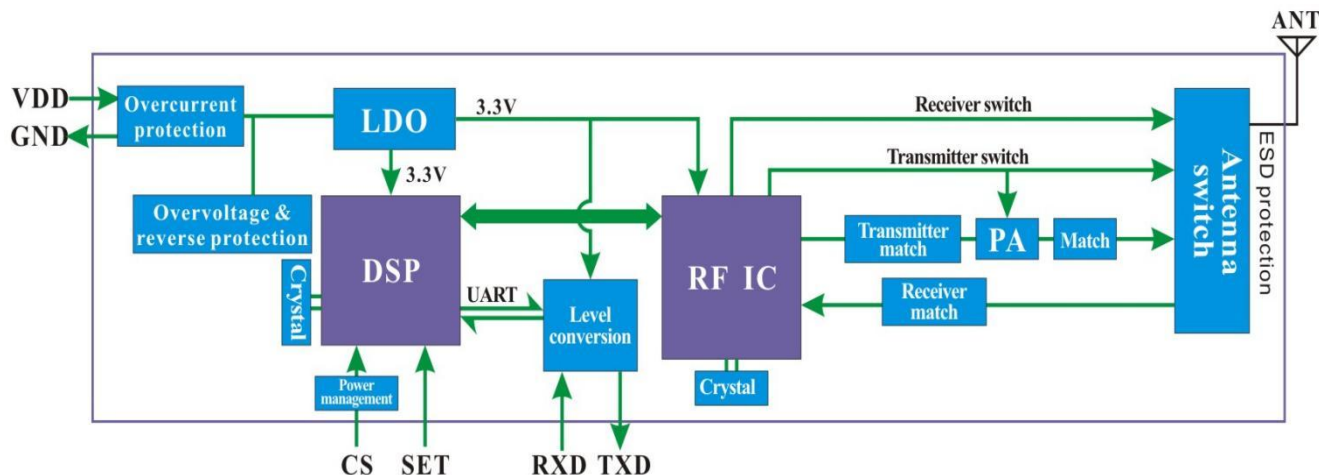

5. Electrical Characteristics

Note: The module is internally regulated by 3.3V LDO. The CS pin and SET pin control are 3.3V levels. TXD and RXD are also 3.3V levels.

Parameters	Min.	Typ.	Max.	Unit	Condition
Working Condition					
Voltage range	3.3	5.0	6.5	V	
Operating Temperature	-40	25	+85	°C	
Current Consumption					
Rx current		<16		mA	@5V,@TTL level
Tx current		< 600		mA	@5V,@TTL level
Sleep current		< 250		uA	Customizable <5 uA version
RF Parameters					
Frequency range	414.92	433.92	453.92	MHz	@433MHz
	470.92	490.92	509.92	MHz	@470MHz
	849.92	868.92	888.92	MHz	@868MHz
	895.92	914.92	934.92	MHz	@915MHz
Data rate	91	656	17353	bps	@LoRa
Output power	+ 24	> 29.5	+ 31	dBm	@5V,@433MHz / 470MHz
	+ 21	> 27	+ 28.5	dBm	@5V,@868MHz / 915MHz
Sensitivity		-139		dBm	@91bps

Remark: If you need lower sleep power consumption, please contact us to send the “sleep current = 15uA” version.

6. Operation

1) Power on Reset

Standard supply voltage of 5V (ordinary lithium battery of 4.2V is also applicable), After powered on reset, the TX LED (Red) and RX LED (Blue) will blink 3 times, (If no lights, module may damaged) ,The total reset time is around 2s, as below:

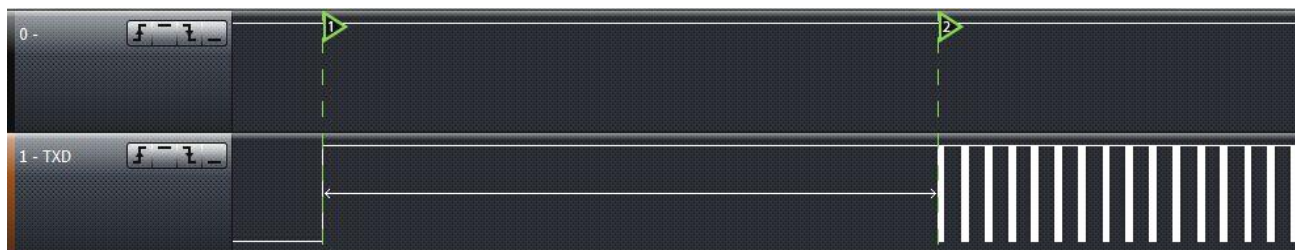

Note: Contact us to customize if you want to shorten the POR time.

2) Working Mode

The upgraded LoRa PRO series can be compatible with all versions of our previous LoRa data transmission. Users can configure the module to their required working mode according to their own application requirements. Now, the simple comparison between several versions is as follows:

Model Number	Feature	Maximum payload length (bytes)	Delay time	Encryption	Routing	LBT	communicate with other module
LoRa series	transparent wireless communication, basic function	200	shortest	xor	No	No	LoRa, LoRa_AES, LoRa_MESH Not interoperable , LoRa Pro Can be configured Interoperate with these three models
LoRa_AES series	AES encryption /decryption added	62	longest	AES	No	No	
LoRa_Mesh series	Mesh function added	150	middle	xor	yes	No	
LoRa-Pro series	newest version , combine all the above function	227	different according to the setting.	configurable	yes	Yes	

So, why is there a difference in wireless transmission time between different versions? Our explanation of the delay time is as follows:

- ✓ LoRa series : It is based on the most basic transmission in the LoRa modulation mode. In addition to the data content, it needs to be added: preamble, synchronization word, checksum, CRC and other packet structure processing;
- ✓ LoRa_AES series : In the above basic content, the AES encryption part is additionally added;
- ✓ LoRa_MESH series: Added part of the Mesh function to the LoRa series;
- ✓ LoRa_Pro series: Can be configured into the above 3, so the delay time will be set according to the settings.

3) Non MESH Data transmission mode

Parameter configuration in Non MESH working mode: Working Mode = Non MESH

In this mode of operation, after a power-on reset (the CS and SET pins of the @ module are left floating or pulled high), the module enters the state of communication, and both the serial port and the RF section are in receive mode.

After the serial port receives the data of the correct baud rate, the module will automatically process the data received by the serial port and then forward it through the wireless circuit (this data packet has been processed by ordinary encryption), then the red indicator light will flash; the other end After the module wireless circuit receives the entire data packet, the blue indicator light will flash. The module will unpack the air data and output it through the serial port (this data has been decrypted, which is the original data transmitted by the serial port), which is a kind of point-to-point and point. Transparent transfer application between multiple points.

The module itself uses a transparent transmission mechanism, without any additional protocol, users can easily send and receive data through the serial port. The module can be directly connected to the PC through the USB adapter board, and the serial port assistant can be used to simulate the data transmission and reception process, as shown in the following:

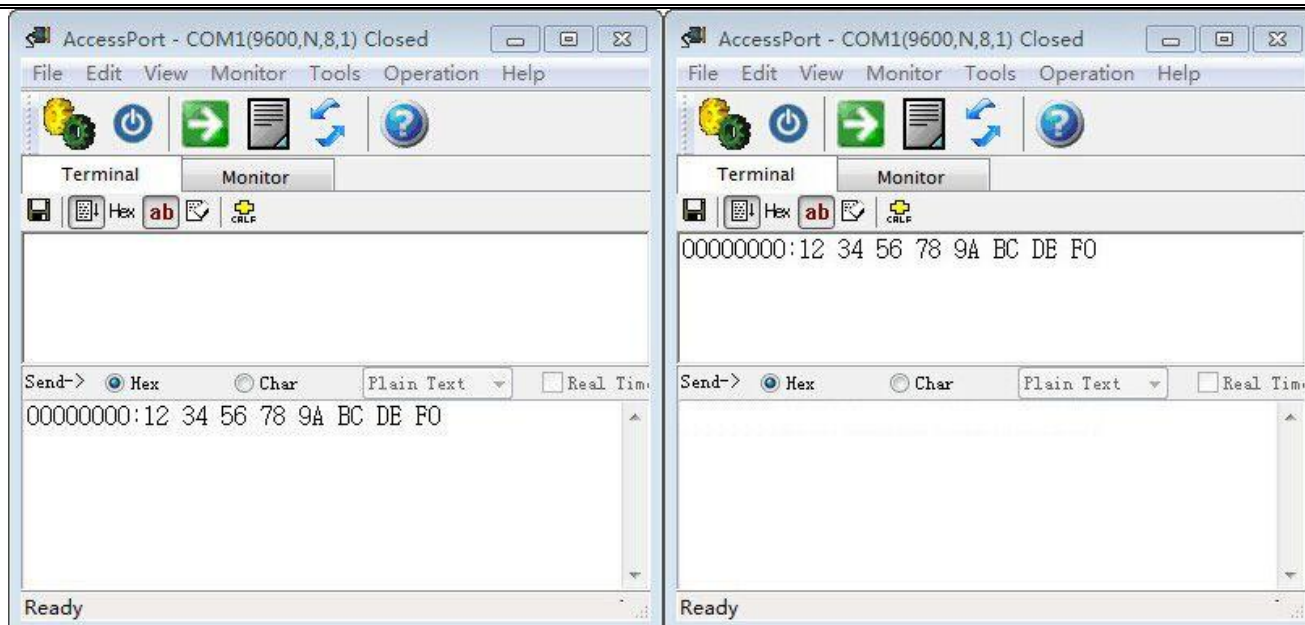

4) MESH network transmission mode

Parameter configuration in MESH networking working mode: Working Mode=MESH

Mode = “Node” or “Router” or “Node & Router”

In MESH mode, the module can be configured into nodes and routes through different modules, and form a MESH network as a whole to realize point-to-point and point-to-multipoint transmission. The node segment module configured as Node mode is similar to the standard communication terminal module. The router-based routing module forwards data in the same network to solve the problem that a single point-to-point transmission distance is insufficient in many practical applications, and there is no limit to the number of routes in the entire network. **The number of hops for routing can be configured as needed.**

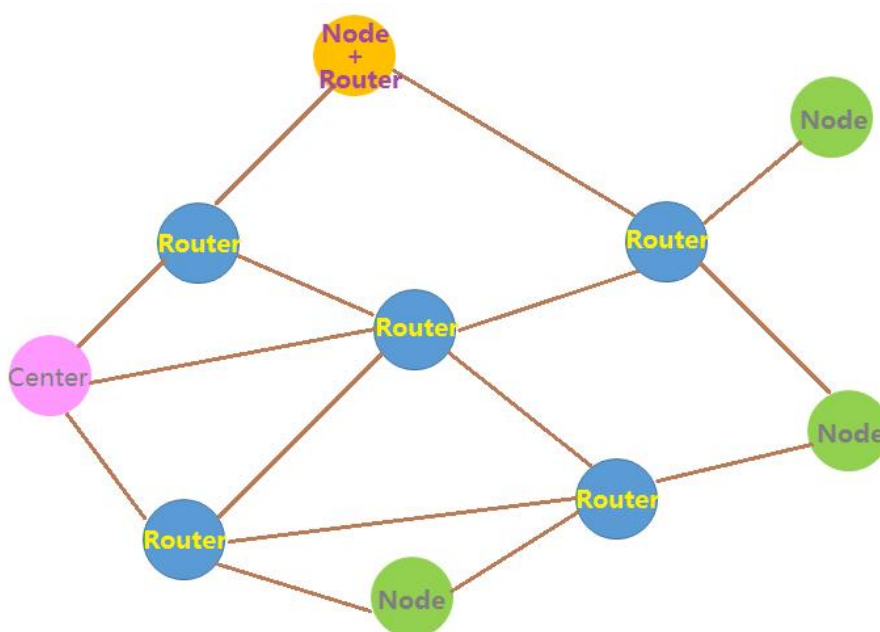

The default hop level is set to 0. The module will transmit the data in the shortest routing and shortest time.

Note:

- ◆ In the same MESH network, all modules including node, route and node+route need to be set with different NODE IDs.
- ◆ There is no limit on the number of hops when hop=0. When Hop=n, the packet can be forwarded up to n times. When HOP>0, the number of hops set by modules in the same MESH network can be different.
- ◆ Modules with hop=0 cannot communicate with modules with hop>0.
- ◆ compatible with older version when set Hop to 0.

5) AES128 data encryption transmission mode

In the wireless communication process, the module can superimpose and enable AES128 encryption in addition to its own data encryption function. The user can freely read or change the module's AES128 key through the PC software. When the AES128 encryption mode is enabled, the wireless transmission delay will be slightly longer, but the protection of the air data is the best. The AES128 encryption function of the module can be enabled by the customer in applications where the transmission data is highly encrypted.

6) LBT Features (Listen Before Talk)

When multiple transmitters are working at the same time, in order to ensure that they do not interfere with each other, The module checks whether other transmitters are transmitting in the environment before transmitting, if other transmitters are transmitting wireless signals. it will not be transmitted temporarily until the other transmitters stop transmission.

- ✓ **Special Note: Due to the limited internal data buffer of the module (200 bytes), if the channel is always busy, the serial port will continue to transmit data to the module, and the data will be overwritten.**

7) Dormancy

When the CS pin of the module is set low, the module is in the sleep state. At this time, the parameter cannot be set and data transmission is not performed. The module has the lowest power consumption in this state, and the current can reach the uA level.

8) CRC encryption

The added CRC encryption can be good solution to avoid wrong data output, especially in the bad environment or multi-nodes transmit data simultaneously.

Note: The CRC configuration needs to be the same.

7. Data transfer overview

In order to ensure the stability and correctness of wireless data transmission, the following points should be noted in use:

a) Wireless transmission matching

The RF module in the same network guarantees normal communication. The frequency band, channel, RF rate, and AES key must be set consistently. If any one of them is different, they cannot communicate with each other. At the same time, the serial port parameters of the module must also be the same as the serial port parameters of the device. Otherwise, communication cannot be performed.

Note: Our default factory setting is: serial port baud rate 9600bps, data bit 8 bits, stop bit 1 bit, no parity bit.

b) Delay in data in wireless communication

Since the wireless communication transmitting end receives a certain amount of data from the terminal device, or waits for a certain time to start transmitting without new data, the data transmission from the wireless communication transmitting end to the wireless communication receiving end also takes time, so the data is transmitted from the transmitting end. There is a certain time delay to the output of the receiver. Under the same conditions, the delay time is fixed (the specific time is determined by the serial port rate, the air rate and the size of the transmitted data packet). The approximate correspondence is also related to the selected working mode, as shown in the following table:

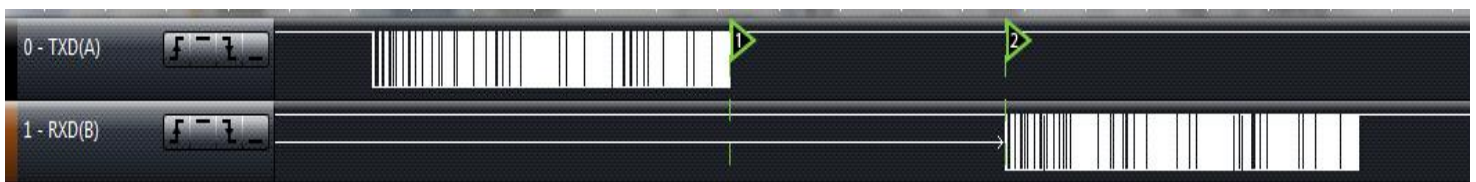

✓ @ Non MESH Data transmission mode

Speed rate	91	164	296	656	830	1557	2932	4750	9501	17353
------------	----	-----	-----	-----	-----	------	------	------	------	-------

1byte time (ms)	2240	1120	561	323	284	144	75	46	25	15
56bytes time (ms)	5847	3089	1711	941	737	392	220	139	73	45

✓ @ AES Encrypted transmission mode

Speed rate	91	164	296	656	830	1557	2932	4750	9501	17353
1byte time (ms)	3251	1641	917	476	435	234	144	94	63	51
56bytes time (ms)	6286	3528	1987	1134	889	545	352	261	190	160

✓ @ MESH Network transmission mode

Speed rate	91	164	296	656	830	1557	2932	4750	9501	17353
1byte time (ms)	2568	1285	726	366	326	166	96	55	30	19
56 bytes time (ms)	6175	3418	1875	1023	778	434	241	150	79	49

Note: If the LBT function is used, the transmission time is based on the above time, and the random delay due to the LBT function needs to be added.

c) Data Flow

The module has a data buffer inside, The module can send up to 227 bytes of data in a single packet and the module can send up to 231 bytes of data in a single time.

LoRa communication can choose to transmit at a lower rate to get a longer communication distance. When sending a large packet, if the serial transmission rate is too high, and the wireless is too slow, there will be data loss. The user can unpack the data and ensure that the interval at which the serial port sends data is greater than the transmission time of the current gear RF.

8. Setting mode

In working mode, pull low the SET pin to force the module into setting mode. When using USB bridge board, simply put on the short cap to enter into setting mode.

In setting mode, both blue and red LED will be light on, shown as below:



Digital transmission module TTL interface connection diagram

- Install the USB driver and PC configuration software.
- Connect the module and the level adapter board of the corresponding interface through the dedicated 6PIN terminal line.
- Plug the USB of the level adapter board into the USB port of the computer and connect it to the PC.
- At this point, the module switches to the configuration mode, and the two-color lamp is always on, as shown in the figure.

In the configuration mode, the user can configure the relevant parameters of the module through the PC software. After the PC software is opened, click to open the corresponding COM port (can be viewed under the device manager), the PC will read the parameter information of the connected module and in the window. The corresponding model and version information is displayed, and the message "Device Found!" is displayed in the status bar below. When the device is unplugged or there is no response, the status bar below displays the message "Device Not Found!", and the product information box above becomes gray invalid. The PC interface after the module is successfully connected is shown below:



After the module is properly connected, the module is in the "settable parameters" state. The user can modify the relevant parameters of the module through the PC interface, such as: working frequency band, transceiver channel, air communication rate, transmission power; serial port baud rate, data bit, stop bit, parity check bit; NET ID, NODE ID, key, etc. Then, click the [SET] button to set the module. After each parameter is successfully changed, the "OK" message will be returned. After the PC software receives the OK response, the prompt dialog box for successful operation will pop up; otherwise, the output "ERROR" will pop up. If the operation error is incorrect, if there is no response within 0.5s after the PC sends the command, a communication error will occur and a dialog box for the

operation error will pop up. These set parameters can be saved after power down. When the user clicks the [READ] button, the module will return all parameter information of the current module. The user clicks the [DEFAULT] button to set the module's parameters to the factory defaults.

(The relevant parameters of the serial port and wireless part in the above PC interface are the factory default values)

In addition to the PC side, the user can also read or modify the relevant parameters of the module online through the UART interface. The serial port sends configuration commands in accordance with the following protocols: Besides PC, user can set all the parameters by their own device. The communication protocol is as below:

Baud rate=9600 bps; Data bit=8 bits Stop bit:1 Parity bit: none

Command format : AA FA + command+[parameters]

Command is 1 byte, parameters are 0 or Hex format.

Return value ended with “\r\n”.

➤ **Command [AA]:**

Read the product model number and version number of the module, without [parameter]

Configuration directive is: AA FA AA

The return value is: “LoRa6100Pro_VER4.0\r\n”

➤ **Command [01]:**

Read the parameters currently set by the module, without [parameter]

Configuration directive is: AA FA 01

The return value is:

Transceiver channel - working frequency band - air communication rate - transmitting power - serial port baud rate - serial data bit - serial port stop bit - serial port check bit - NET ID - NODE ID - MESH - NODE - AES - key \r \n

➤ **Command[02]:**

Restore the factory default parameters of the module, without [parameter]

Configuration directive is: AA FA 02

The return value is: “OK\r\n”or“ERROR\r\n”

The default parameter is:

Receive/transmit operating frequency = 433.92 MHz Receive/transmit transmission rate = 656 bps
Transmit power = Level 7 (highest)

Baud rate=9600 bps; Data bit=8 bits Stop bit:1 Parity bit: none

NET ID = 00 00 00 00 NODE ID = 00 00 MESH = 00 NODE = 00 AES = 00

Key = 00 00 00 00 00 00 00 00 00 00 00 00 00 00 00 00

LBT enable = 0

➤ **Command[03]:**

Parameter setting command, with [parameter] of 33 bytes, the sequence is as follows:

Transceiver channel - working frequency band - air communication rate - transmitting power - serial port baud rate - serial data bit - serial port stop bit - serial port check bit - NET ID - NODE ID - MESH - NODE - key type - 16 byte key

Configuration directive is: AA FA 03 XX XX XX XX XX XX XX XX XX XX XX XX XX XX XX XX

The return value is: "OK\r\n" or "ERROR\r\n"

1) **Channel:** RF frequency

Each frequency band is divided into 40 channels, and the adjacent channels have a difference of 1 MHz. The specific corresponding frequencies are shown in the following table:

Band	Channel	1	2	3	4	5	6	7	8	9	10	
433	Frequency(MHz)	414.92	415.92	416.92	417.92	418.92	419.92	420.92	421.92	422.92	423.92	
	Channel	11	12	13	14	15	16	17	18	19	20	
	Frequency(MHz)	424.92	425.92	426.92	427.92	428.92	429.92	430.92	431.92	432.92	433.92	
	Channel	21	22	23	24	25	26	27	28	29	30	
	Frequency(MHz)	434.92	435.92	436.92	437.92	438.92	439.92	440.92	441.92	442.92	443.92	
	Channel	31	32	33	34	35	36	37	38	39	40	
490	Frequency(MHz)	444.92	445.92	446.92	447.92	448.92	449.92	450.92	451.92	452.92	453.92	
	Band	Channel	1	2	3	4	5	6	7	8	9	10
	490	Frequency(MHz)	470.92	471.92	472.92	473.92	474.92	475.92	476.92	477.92	478.92	479.92
		Channel	11	12	13	14	15	16	17	18	19	20
		Frequency(MHz)	480.92	481.92	482.92	483.92	484.92	485.92	486.92	487.92	488.92	489.92
		Channel	21	22	23	24	25	26	27	28	29	30
Frequency(MHz)		490.92	491.92	492.92	493.92	494.92	495.92	496.92	497.92	498.92	499.92	
Channel		31	32	33	34	35	36	37	38	39	40	
868	Frequency(MHz)	500.92	501.92	502.92	503.92	504.92	505.92	506.92	507.92	508.92	509.92	
	Band	Channel	1	2	3	4	5	6	7	8	9	10
	868	Frequency(MHz)	849.92	850.92	851.92	852.92	853.92	854.92	855.92	856.92	857.92	858.92
		Channel	11	12	13	14	15	16	17	18	19	20
		Frequency(MHz)	859.92	860.92	861.92	862.92	863.92	864.92	865.92	866.92	867.92	868.92
		Channel	21	22	23	24	25	26	27	28	29	30
Frequency(MHz)		869.92	870.92	871.92	872.92	873.92	874.92	875.92	876.92	877.92	878.92	
Channel		31	32	33	34	35	36	37	38	39	40	
868	Frequency(MHz)	879.92	880.92	881.92	882.92	883.92	884.92	885.92	886.92	887.92	888.92	

Band	Channel	1	2	3	4	5	6	7	8	9	10
915	Frequency(MHz)	895.92	896.92	897.92	898.92	899.92	900.92	901.92	902.92	903.92	904.92
	Channel	11	12	13	14	15	16	17	18	19	20
	Frequency(MHz)	905.92	906.92	907.92	908.92	909.92	910.92	911.92	912.92	913.92	914.92
	Channel	21	22	23	24	25	26	27	28	29	30
	Frequency(MHz)	915.92	916.92	917.92	918.92	919.92	920.92	921.92	922.92	923.92	924.92
	Channel	31	32	33	34	35	36	37	38	39	40
	Frequency(MHz)	925.92	926.92	927.92	928.92	929.92	930.92	931.92	932.92	933.92	934.92

2) Working Band: RF Frequency center point

There are 4 working frequency bands, as shown in the following table:

Parameter	01	02	03	04
Band	433 MHz	490 MHz	868 MHz	915 MHz
	414.92 ~ 453.92	470.92 ~ 509.92	849.92 ~ 888.92	895.92 ~ 934.92

Note: The matching network and antenna are different in different frequency bands. In order to ensure the communication performance of the module, the central frequency band cannot be changed at will.

3) RF data rate: RF Data transmission speed

Set the wireless transmission rate, [parameter] occupies 1 byte.

Setting range: 91 164 296 656 830 1557 2932 4750 9501 17353 bps

Parameter	0	1	2	3	4	5	6	7	8	9
Data Rate	91	164	296	656	830	1557	2932	4750	9501	17353

TX power : This parameter will affect the communication distance (the higher the power, the farther the module communication distance is)

Set the transmit power, [parameter] occupies 1 byte. Setting range: 0-7.

TX Power level	0	1	2	3	4	5	6	7
433MHz	24.6	27	27.9	28.6	29.2	29.6	29.9	30.1
868MHz	21.3	24.2	25.6	26.3	26.7	27.3	27.3	27.5
915MHz	20.8	23.7	25.1	26	26.6	27	27.1	27.2

4) Serial baud rate

Set the transmission rate of the serial interface. [Parameter] occupies 1 byte.

Setting range: 1200 2400 4800 9600 14400 19200 38400 57600 76800 115200 bps

Parameter	0	1	2	3	4	5	6	7	8	9
Rate(bps)	1200	2400	4800	9600	14400	19200	38400	57600	76800	115200

5) Serial data bit

Set the data bit of the serial port, [parameter] occupies 1 byte. Setting range: 7 digits 8 digits 9 digits

Parameter	1	2	3
Data bit	7 digits	8 digits	9 digits

6) Serial stop bit

Set the stop bit of the serial port, [parameter] occupies 1 byte. Setting range: 1 bit 2 bits

Parameter	1	2
Stop	1 bit	2 bit

7) Serial parity bit

Set the parity bit of the serial port. [Parameter] is 1 byte. Setting range: No Odd Even

Parameter	1	2	3
Parity test	No	Odd	Even

8) NET ID

Set the network ID of the RF packet. [Parameter] is 4 bytes.

The NET ID of the module is inconsistent and cannot be communicated. Setting range: 00 00 00 00 ~ FF FF FF FF

9) NODE ID

In MESH mode, you must ensure that the NODE ID of each module in the network is different, otherwise you cannot communicate.

Set the node ID of the RF packet, [parameter] is 2 bytes. Setting range: 00 00 ~ FF FF

10) Working mode :

Normal operation mode or MESH networking mode, [parameter] is 1 byte. Setting range: 00 01

Parameter	0	1
Working mode	Non MESH	MESH

Note: The module with the MESH networking function turned off and the module with the MESH networking function enabled cannot communicate. To ensure communication, the MESH networking functions in the same network should be consistent.

11) Mode selection:

Set the working mode in MESH mode. This option is valid only when the MESH networking function is turned on.

[Parameter] is 1 byte. Setting range: 0~2

Parameter	0	1	2
Working mode	node	routing	routing+node

12) Encryption selection:

Set whether to enable AES encryption. [Parameter] is 1 byte. Setting range: 00 01

Parameter	0	1
AES encryption	close	open

13) Key: Set the wireless data encryption key, [parameter] is 16 bytes.

Setting range: 0 ~ FF FF FF FF FF FF FF FF FF FF FF FF FF FF FF

Default factory value: 000102030405060708090A0B0C0D0E0F

➤ **Command [04] Read RSSI value**

When the module is switched to the configuration state, the RF will detect the surrounding field strength signal in real time, and the user can send the corresponding command to get the RSSI value through the serial port.

The instruction to get the current instantaneous field strength value of the module.

Read command is: AA FA 04

The return value is: RSSI value \r\n (displayed in characters, range 000~255)

For example: "-032\r\n", indicating that the current signal strength value is -32dBm.

➤ **Command [05] Read LBT status**

Read the LBT parameter currently set by the module, without [parameter]

Configuration directive is: AA FA 05

The return value is: LBT Enable\r\n

For example: Return 01 0D 0A , indicating that idle detection is enabled.

➤ **Command [06] LBT Enable/Disable**

Parameter setting command, with [parameter] 1 byte, parameter: idle detection enable

When LBT function is enable, the module won't transmit the message until there is no signal transmitting in the air.

Configuration directive is: AA FA 06 XX

Return instruction: "OK\r\n" or "ERROR\r\n"

For example: Enable LBT enable, should be sent in hexadecimal: AA FA 06 01

LBT enable

Enable idle detection, [parameter] is 1 byte. Setting range: 0~1

Parameter	0	1
LBT enable	close	open

➤ Instruction [07]

Read the number of hops level, without [parameter]

Command is: AA FA 07

Return: hop number \r\n

For example:

AA FA 07

02 0D 0A

➤ Instruction [08]

Set number of stages command, with [parameter] of 1 byte, parameter is: the number of forwarding stages

Configuration command: AA FA 08 XX

Return : "OK\r\n" or "ERROR\r\n"

For example, if the number of forwarding hops is set to 2, it should be sent in hexadecimal:

AA FA 08 02

Number of forwarding hops: [Parameter] is 1 byte. Setting range: 0~16

➤ Instruction [09]

Read the CRC status

Command : AA FA 09

Return: 01(00) \r\n ; 01 means enable , 00 means disable.

For example: Return: 01 0D 0A, CRC is enable.

➤ **Instruction [0A]**

(The CRC enable/ disable command

Command is: AA FA 0A XX ; XX = 01 or 00.

Return command: "OK\r\n" or "ERROR\r\n"

For example,

Command : AA FA 0A 01

Return : OK\r\n ; CRC is enable.

CRC enable: open/close CRC, [parameter]is 1byte.Setting range: 0~1

Parameter	0	1
CRC enable	close	open

9. Pin definition

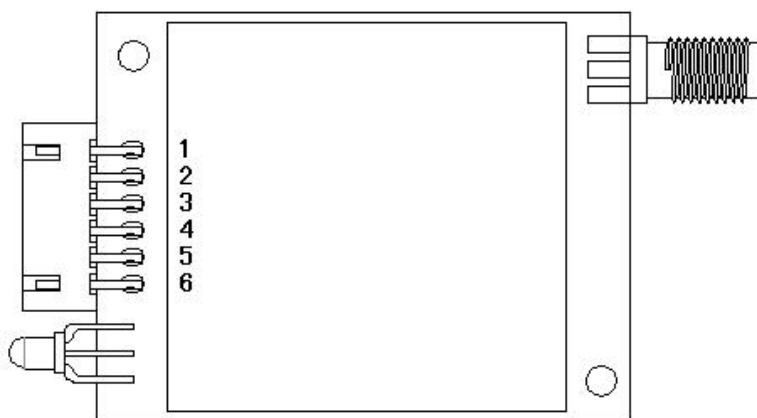

Pin No.	Definition	Description
1	VCC	Connected to the positive power supply (typical 5V)
2	GND	Connected to ground
3	TXD/A	connect to A@485
4	RXD/B	connect to B@485
5	SET	Configuration parameter enable (low level enable parameter configuration, default high level output)
6	CS	Module enable pin (built-in pull-up) Note: Default factory version: sleep current <200uA, CS pulled high or suspended for normal communication, sleep at low level; Low power consumption version: sleep current <15uA, normal communication when CS is pulled low, pull high or float to sleep.

10. Typical Application circuit

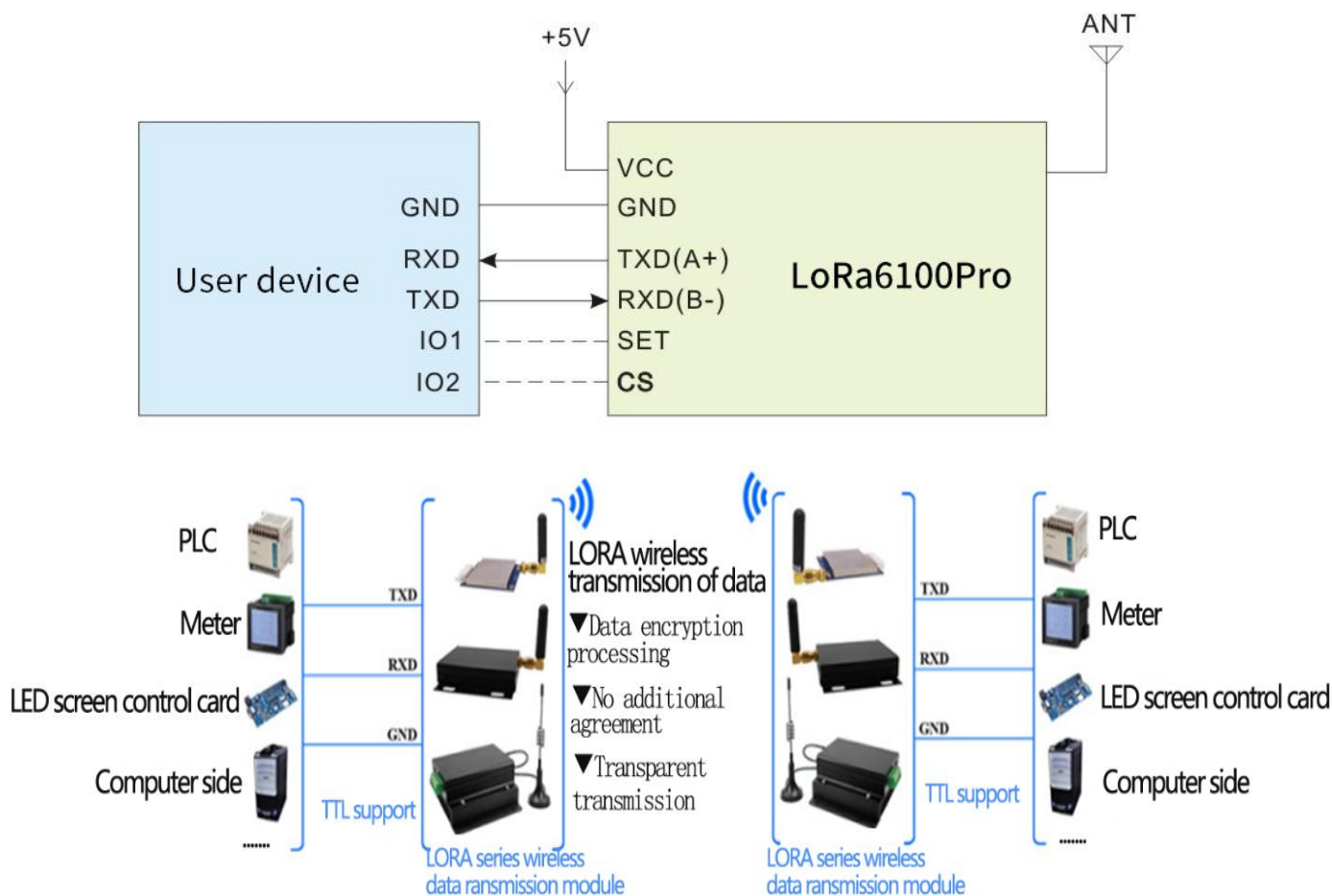

(Typical application diagram)

Note: The ground wire of the module must be connected to the digital ground of the device.

11. Accessories

1) Antenna

The antenna is an important part of the communication system. Its performance directly affects the parameters of the communication system. The antenna impedance required by the module is 50 ohms. The universal antenna has a spring antenna, and can also be used to connect the straight head/elbow/folding rod shape, small suction cup, etc. through SMA. Users can purchase the antenna according to their own application environment. In order to make the module work in the best working condition, it is recommended to use this. The antenna provided by the company.



★ Tips for antenna:

- Don't close to the ground, metal, magnet, big current;
- If you are using the sucker antenna, pull the wire as straight as possible, the sucker foundation should stick with metal

2) USB bridge board

There are 3 type of USB bridge, which is SU108-TTL/ SU108-232 / SU108-485. SU108 -TTL is for TTL Interface, SU108-232 is for 232 Interface, SU108 - 485 is for 485 Interface. User should select the right USB Bridge corresponding to the RF module. The product is shown below:

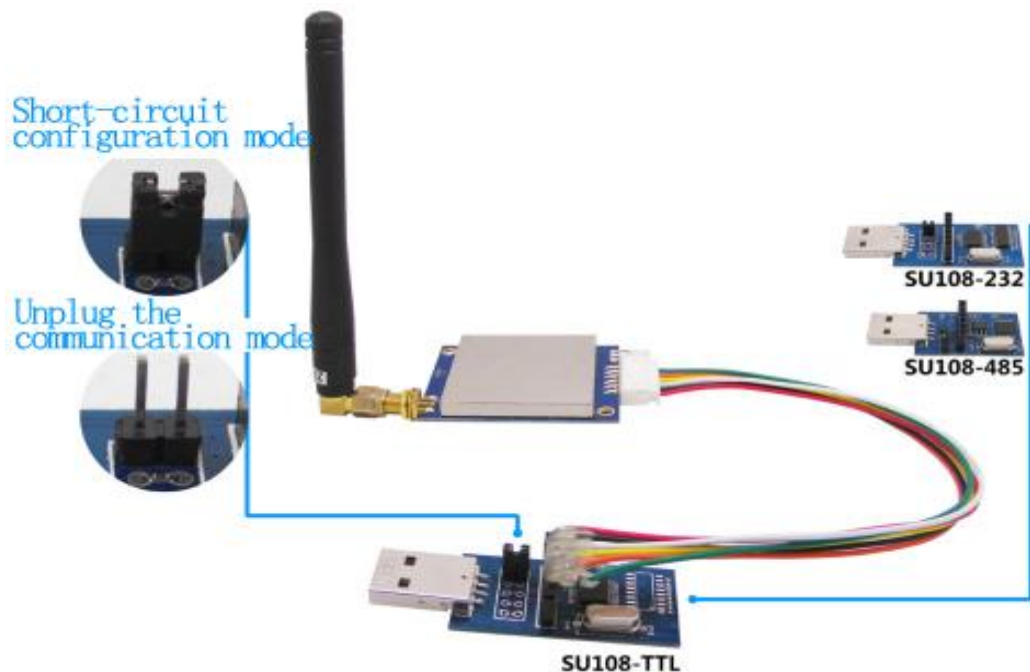

12. Mechanical dimension(Unit: mm)

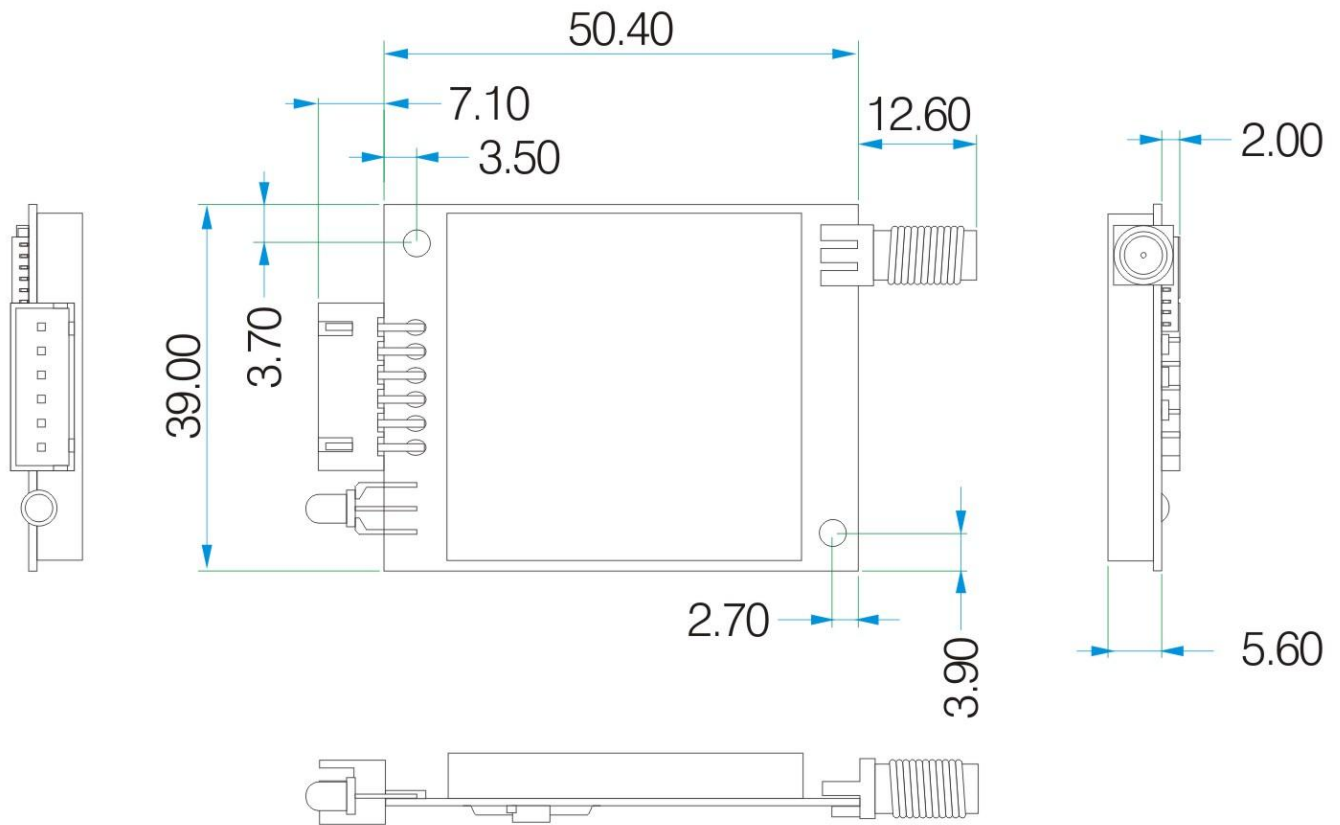

13. Order information

For example:

Customers need 485 interface, 433MHz band module, the order model is: LoRa6100Pro-485-433.

Product Name	Description
LoRa6100Pro-TTL-433	433MHz, TTL interface
LoRa6100Pro-232-433	433MHz, 232 interface
LoRa6100Pro-485-433	433MHz, 485 interface
LoRa6100Pro-TTL-490	490MHz, TTL interface
LoRa6100Pro-232-490	490MHz, 232 interface
LoRa6100Pro-485-490	490MHz, 485 interface
LoRa6100Pro-TTL-868	868MHz, TTL interface
LoRa6100Pro-232-868	868MHz, 232 interface
LoRa6100Pro-485-868	868MHz, 485 interface
LoRa6100Pro-TTL-915	915MHz, TTL interface
LoRa6100Pro-232-915	915MHz, 232 interface
LoRa6100Pro-485-915	915MHz, 485 interface

14. FAQ

- Why module can not communicate properly?
 - a) Check if the band, channel, rate, NET ID has set to the same;
 - b) Check if there is power connection error;
 - c) Check if the module is enabled (CS high);
 - d) Check if the antenna connection is not correct;
 - e) Check if the module is damaged.
- Why transmission distance is not far as it should be?
 - a) Power supply ripple is too large;
 - b) The antenna types do not match, or not properly installed;
 - c) The surrounding environment is harsh, strong interference sources;
 - d) Surrounding co-channel interference;
- Why receiving data incorrect?
 - a) Improper parameter settings;
 - b) Module data interface is bad.