

Technical Datasheet Input / Output Modules with Modbus RTU Protocol with RS485 Interface

The IO modules communicate via RS485. The port can drive distances up to max 700 meters without the use of any repeater (*this feature however also depends on the signal strength of the Modbus Master Device*).

The RS485 Digital IO module is sturdy, low power usage and easy to use.

8 Port DI Module: -



The IO modules are mounted on DIN rail mountable casing and with exposed connectors and LED indicators. The DIP switch for Slave ID and Baud rate are placed inside the enclosure.

The design of the modules incorporates '**resettable Fuses**' to safeguard against reverse polarity connection both for **Power** and **Communication** port.

Specifications

General –

I/O Connectors

2 Pin 5.08 mm pitch pluggable screw Terminal Block

Dimensions

60 mm L x 110 mm B x 50 mm H

Power

Input Power – 12 – 24 VDC or 24 V AC/DC

Typical – 12V DC @ 80mA

Operating Temperature 0 – 60° C (32 ~ 140°F)
Storage Temperature -20 - 70° C (-4 ~ 158°F)
Storage Humidity 5 ~ 95 % RH, non – Condensing

Certifications

DI Inputs –

Channels 8
Sense Voltage 3.3 – 30 VDC
Sense Logic Logic '0' = <1 VDC, Logic '1' = >3.3 VDC
Isolation Optically isolated
Response Time 2 msec, Max 6 msec

Additional Features: -

All inputs and communication port isolated
Input power reverse polarity safety
ESD Safety IEC 61000-4-2, ± 30KV contact, ± 30KV air
EFT IEC 61000-4-4, 50A (5/50ms)
750V isolation.
CRC Error check.
No configuration needed on the IO board

Configuration Settings: -

Communication Speed 9600 – 19200 Kbps (DIP SW selectable)
Data Bits 8
Parity None
CRC Yes
Stop bit 1
Slave ID 1-15 (DIP SW Selectable)
Function code DI 0x02 Read discrete Input
DI Register Address 0,1,2,3,4,5,6,7.

ID	Function Description	Register Description	Modbus Function Code	Protocol	Data Type
1	DI 1(With & Without Potential)	10001	0X02	RS485	1 Bit Boolean
2	DI 2(With & Without Potential)	10002	0X02	RS485	1 Bit Boolean

3	DI 3(With & Without Potential)	10003	0X02	RS485	1 Bit Boolean
4	DI 4(With & Without Potential)	10004	0X02	RS485	1 Bit Boolean
5	DI 5(With & Without Potential)	10005	0X02	RS485	1 Bit Boolean
6	DI 6(With & Without Potential)	10006	0X02	RS485	1 Bit Boolean
7	DI 7(With & Without Potential)	10007	0X02	RS485	1 Bit Boolean
8	DI 8(With & Without Potential)	10008	0X02	RS485	1 Bit Boolean

Note: -

For MODBUS communications, a **shielded and twisted pair cable** is used. One example of such cable is Belden 3105A

Recommended Cable Electrical Characteristics: -

22 AWG Cable Shielded and twisted pair
Tinned Copper Recommended
Nominal Conductor DCR 14.7 ohm / 1000 ft
Nominal Capacitance 11 pf / feet (conductor to conductor)
High Frequency Non-Insertion Loss 0.5db / 100ft

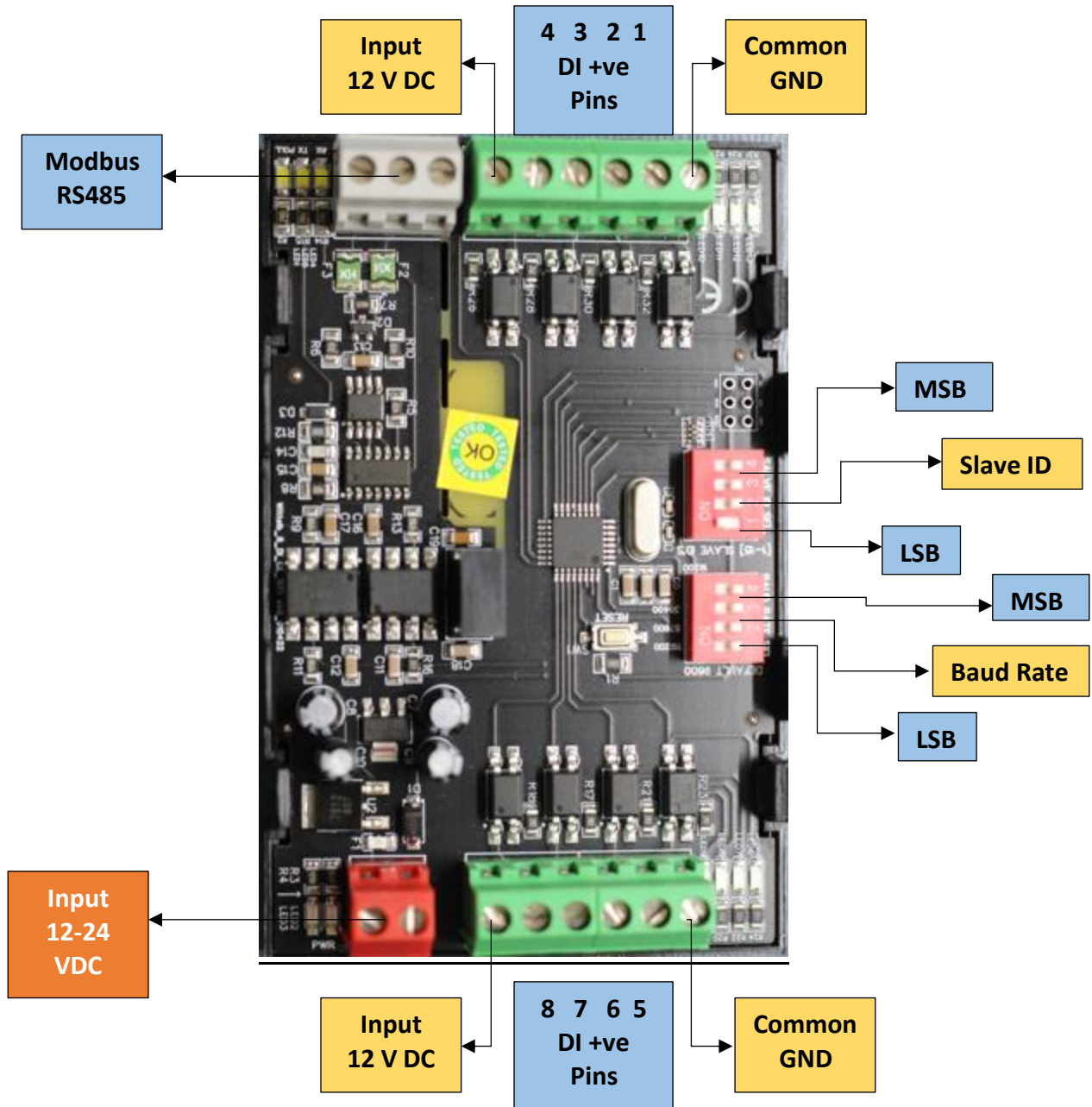

BAUD RATE DESCRIPTION

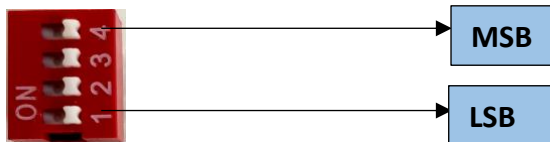

- For Baud rate Selection, DIP SW is used as per the diagram.
- Pulling up the switch will make Baud rate active.
- If no selection is made 9600 will be default Baud rate.
- When u change the Baud rate in the Module power 'ON' condition, pls press the reset button to get Change to affect.

Baud Rate	DIP SWITCH			
	1	2	3	4
9600	OFF	OFF	OFF	OFF
19200	ON	OFF	OFF	OFF
38400	OFF	ON	OFF	OFF
57600	OFF	OFF	ON	OFF
115200	OFF	OFF	OFF	ON

SLAVE ID DESCRIPTION

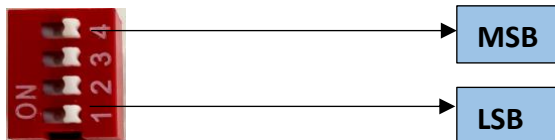

For Slave ID Selection SW is used to Set The SLAVE ID .

For Slave ID DIP Switch **LSB is "1"** follow through **"4" is MSB**.

Slave ID Confirmed through below Device ID table .

IF Eg. Slave ID 1 is Needed to be selected Switch number 1 should pulled up other three should be selected down side. So "1 0 0 0" will be selected as Slave ID 1.

Slave ID	DIP SWITCH				OUTPUT (Binary)	OUTPUT (Decimal)
	1	2	3	4		
0	OFF(0)	OFF(0)	OFF(0)	OFF(0)	1 0 0 0	1
1	ON(1)	OFF(0)	OFF(0)	OFF(0)	1 0 0 0	1
2	OFF(0)	ON(1)	OFF(0)	OFF(0)	0 1 0 0	2
3	ON(1)	ON(1)	OFF(0)	OFF(0)	1 1 0 0	3
4	OFF(0)	OFF(0)	ON(1)	OFF(0)	0 0 1 0	4
5	ON(1)	OFF(0)	ON(1)	OFF(0)	1 0 1 0	5
6	OFF(0)	ON(1)	ON(1)	OFF(0)	0 1 1 0	6
7	ON(1)	ON(1)	ON(1)	OFF(0)	1 1 1 0	7
8	OFF(0)	OFF(0)	OFF(0)	ON(1)	1 0 0 0	8
9	ON(1)	OFF(0)	OFF(0)	ON(1)	1 0 0 1	9
10	OFF(0)	ON(1)	OFF(0)	ON(1)	1 0 1 0	10
11	ON(1)	OFF(0)	ON(1)	ON(1)	1 0 1 1	11
12	OFF(0)	OFF(0)	ON(1)	ON(1)	1 1 0 0	12

13	ON(1)	OFF(0)	ON(1)	ON(1)	1 1 0 1	13
14	OFF(0)	ON(1)	ON(1)	ON(1)	1 1 1 0	14
15	ON(1)	ON(1)	ON(1)	ON(1)	1 1 1 1	15

Connection Instruction FOR DI

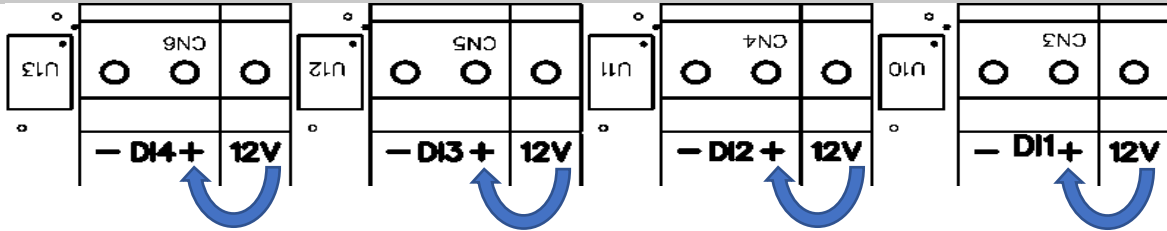

For Digital Input Potential Free Contact Detection 12V & + terminals should be connected, e.g. 12v & DI1+ve terminal.

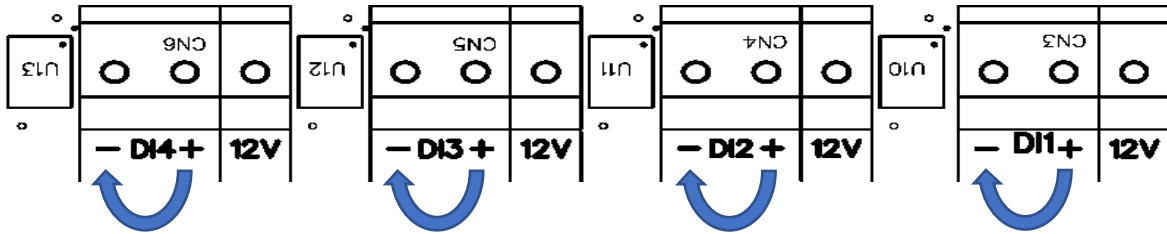

For Digital Input with Potential (3V to 30V) Contact + Common GND terminal should be connected on the Board, e.g DI1 +ve terminal and GND pin.

Contact us: -

Augmatic Technologies Pvt. Ltd.,
Plot no 6, Shah Industrial Estate II,
Kotambi,
Vadodara – 391510.
Email – Sales@wittelb.com