

# Product Specification

**Product Name:** P3 indoor full color module

**Manufacturer:** Shanxi High-tech Huaye Electronics Group Co.,Ltd

**Specification:** M3-I

**File No.:** HJ-03-RD-G-016

**Version No.:** A0

Designed by	Reviewed by	Authorized by
<b>Document release date: Sep 8th, 2022</b>		

## Contents

<b>Scope of Application .....</b>	<b>错误！未定义书签。</b>
<b>Product Description .....</b>	<b>错误！未定义书签。</b>
<b>Interface Definition .....</b>	<b>2</b>
<b>Specification Definition .....</b>	<b>错误！未定义书签。</b>
<b>Module Technical Parameter .....</b>	<b>错误！未定义书签。</b>
<b>Installation Instruction .....</b>	<b>错误！未定义书签。</b>
<b>Module Installation Position Hole Diagram</b>	<b>错误！未定义书签。</b>
<b>Module Installation Requirements .....</b>	<b>错误！未定义书签。</b>
<b>Cabinet Installation .....</b>	<b>错误！未定义书签。</b>
<b>Fixed Module Screw .....</b>	<b>错误！未定义书签。</b>
<b>Module Installation Clearance .....</b>	<b>错误！未定义书签。</b>
<b>Magnetic Column Installation .....</b>	<b>错误！未定义书签。</b>
<b>Magnetic Column Requirements .....</b>	<b>错误！未定义书签。</b>
<b>Module Magnetic Installation .....</b>	<b>错误！未定义书签。</b>
<b>Module Signal Line Connection Method .....</b>	<b>错误！未定义书签。</b>
<b>Module Power Configuration .....</b>	<b>错误！未定义书签。</b>
<b>Switching Power Supply Connection .....</b>	<b>错误！未定义书签。</b>
<b>Display installation method .....</b>	<b>错误！未定义书签。</b>
<b>Wall Mount Installation .....</b>	<b>错误！未定义书签。</b>
<b>Frame Magnetic Strip Screen Installation .....</b>	<b>错误！未定义书签。</b>
<b>Inlay installation .....</b>	<b>错误！未定义书签。</b>
<b>Seat Installation .....</b>	<b>错误！未定义书签。</b>

**Display Installation Precautions.....错误！未定义书签。**

**Waterproof and Moistureproof..... 错误！未定义书签。**

**Ventilation and Cooling..... 错误！未定义书签。**

**Software Installation..... 错误！未定义书签。**

**Safety Requirements..... 错误！未定义书签。**

**Module Usage Safety Requirements..... 错误！未定义书签。**

**Installation Electrostatic Protection Requirements..... 错误！未定义书签。**

**Installation Grounding Requirements..... 错误！未定义书签。**

**Module Cleaning Requirements..... 错误！未定义书签。**

**Maintenance Requirements..... 错误！未定义书签。**

**Anti-collision Requirements..... 错误！未定义书签。**

**Safety Requirements for Display Use..... 错误！未定义书签。**

**Environment Temperature Requirements..... 错误！未定义书签。**

**Display Content Requirements..... 错误！未定义书签。**

**Power Connection Requirements..... 错误！未定义书签。**

**Screen Acceptance Requirements and Methods错误！未定义书签。**

**Display Brightness Acceptance..... 错误！未定义书签。**

**Visual Angle Acceptance..... 错误！未定义书签。**

**Ground Check.....19**

**Lightning Protection Facility Inspection..... 错误！未定义书签。**

**Anti-burn-in Operation Requirements.....错误！未定义书签。**

**Standard Operation..... 错误！未定义书签。**

**Live Installation Operation..... 错误！未定义书签。**

**The display is abnormal when the whole screen is used 错误！未定义书签。**

## Scope of Application

This product specification is only applicable to indoor P3 full-color modules, specification model M3-I.

## Product Description

This product uses SMD2020 full-color lamp beads, with one red, green, and blue chip packaged in the lamp bead. The 2020 lamp beads are soldered on the PCB by surface mount technology (SMT).

This product uses dual latch driver IC chips and integrated line driver chips to be controlled by computer; the display viewing angle is wide, the color is pure and consistent, the brightness is stable and uniform, and the text, image and video are clear.

The lamp beads and chips are mounted on the PCB board to form a unit board, and then mounted on the bottom case to form a module. Its appearance is exquisite and beautiful, sturdy and durable.

The bottom case has M4 threaded holes for installing modules. The magnetic column can be installed on the module, and then assembled into a whole screen, or the module can be fixed on the box body with screws, and then the box body can be spliced into a whole screen.

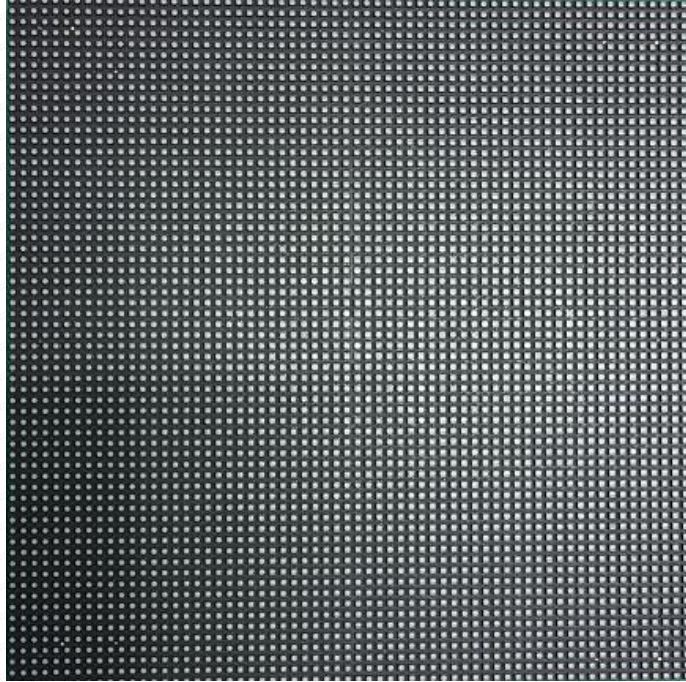

Front View



Rear View

Lamp beads parameter

Item	Unit	R	G	B
IF	mA	10	5	5



Wavelength	nm	617-622	521-526	466-471
lv	mcd	38-53	130-180	29-40
Vf	V	1.8-2.3	2.6-3.2	2.6-3.2

**Interface Definition**

R1	1	2	G1
B1	3	4	GND
R2	5	6	G2
B2	7	8	E
A	9	10	B
C	11	12	D
CLK	13	14	LAT
OE	15	16	GND

Pin	Signal	Function	Pin	Signal	Function
1、2、3	R1 G1 B1	First group data of RGB	4、16	GND	Ground
5、6、7	R2 G2 B2	Second group data of RGB	8、9、10、11、12	E、A B、C D	Line control signal
13	CLK	Clock signal	14	LAT	Data latch
15	OE	Enable signal			

**Specification Definition**

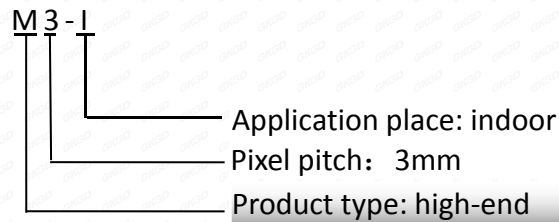

**Module Technical Parameter**

No.	Item	Parameter
Unit Module		
1	LEDSMD	SMD2020 surface mount three in one
2	Horizontal viewing angle	$H \geq 160^\circ$
3	Vertical viewing angle	$V \geq 140^\circ$
4	Pixel composition	1R1G1B
5	Pixel pitch	3mm
6	Scan method	1/32
7	Drive mode	Constant current drive

8	Resolution	64×64
9	Module size	192mm×192mm×14mm
10	Weight	230g±5g
11	Type	Light and drive in one
12	Working voltage	4.5V-5V
13	Average power	7W
14	Maximum power	15W
Whole Screen		
1	Use environment	Indoor
2	White balance brightness	≥500cd/m <sup>2</sup>
3	Color temperature	3000-18000K
4	Average power	204W/m <sup>2</sup>
5	Maximum power	408W/m <sup>2</sup>
6	Brightness uniformity	≥97%
7	Chromatic uniformity	±0.003Cx, within Cy
8	Pixel density (dots/m <sup>2</sup> )	111111
9	Power supply	AC200-240V, 50/60Hz
10	Earth leakage current	≤3.5mA/m <sup>2</sup>
11	Working temperature	-20℃~40℃
12	Working humidity	10%~60%
13	Storage environment temperature	-20℃~60℃
14	Storage environment humidity	10%~60%
15	Frame rate	60Hz
16	Refresh rate	≥1920Hz
17	Viewing distance	≥3m
18	Signal processing depth	16384
19	Grayscale/Color	281trillion
20	Brightness adjustment software	Software 16-level adjustment / 16-level automatic

21	Control method	Synchronized display with computer display
22	Effective communication distance without relay	The maximum transmission distance of unshielded twisted pair is 100 meters, the transmission distance of multi-mode fiber can reach 500 meters, and the transmission distance of single-mode fiber can reach 15 kilometers
23	Computer operating system	Windows (XP、Vista)、Win7、Win8、Win10
24	Video signal	VGA、DVI、RF、S-Video、RGBHV YUV、YC、COMPOSITION etc.,.
25	Mean time between failures	$\geq 10000H$
26	Service life	$\geq 100000H$
27	Pixel runaway rate	$\leq 1/100000$
28	Continuous runaway point	0
29	Discrete runaway point	$< 0.0001, 0$ at factory
30	Stability	Support 7*24H continuous work
31	Flame retardant (fireproof)	The flame retardant rating of PCB reaches UL94 V-0 level
32	Kit Material	PC+fiber
33	Decay rate (working 3 years)	$\leq 15\%$



## Installation Instruction

### Module Installation Position Hole Diagram

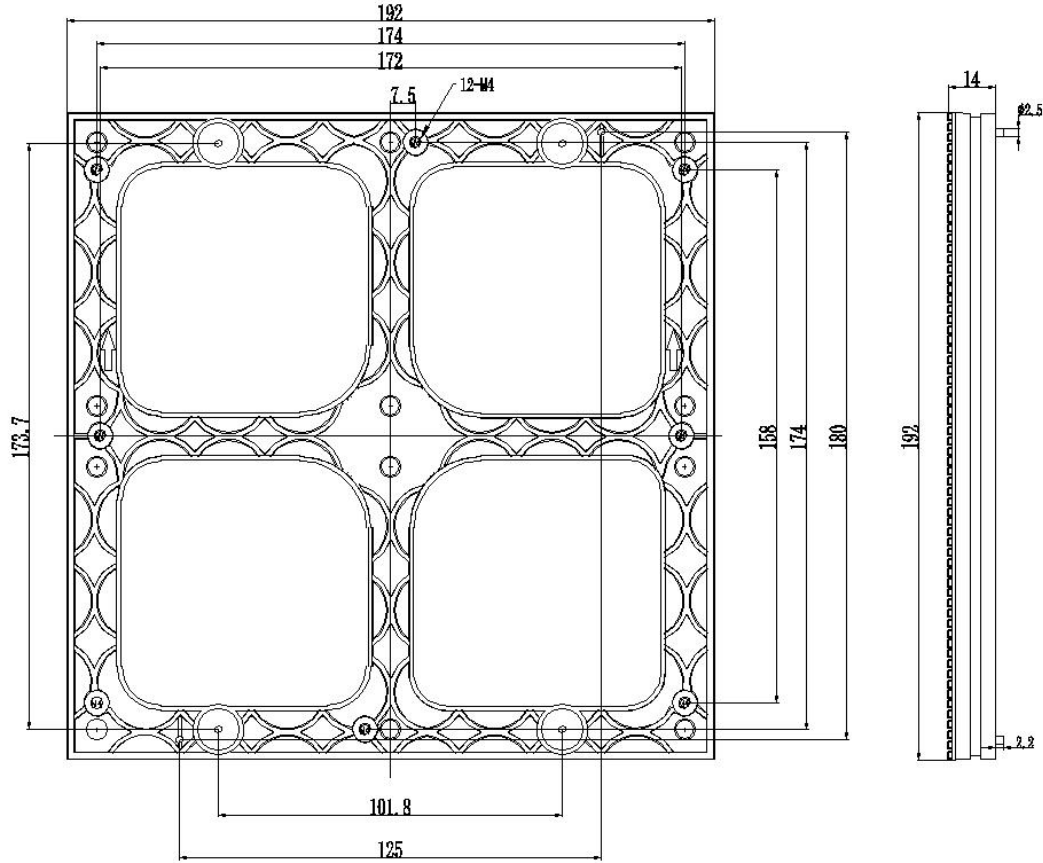

Unit: mm

### Module Installation Requirements

#### Cabinet Installation

The upper direction of the module is the same as the upper direction of the box. The mounting threaded holes on the back of the module are aligned with the corresponding mounting holes of the box. Use M4 screws to fix the module on the box from the inside of the box. The modules must be neatly arranged and the surface of the modules is flat.

After the box is installed, install the box on the steel frame to assemble the display screen, as shown in the figure below.

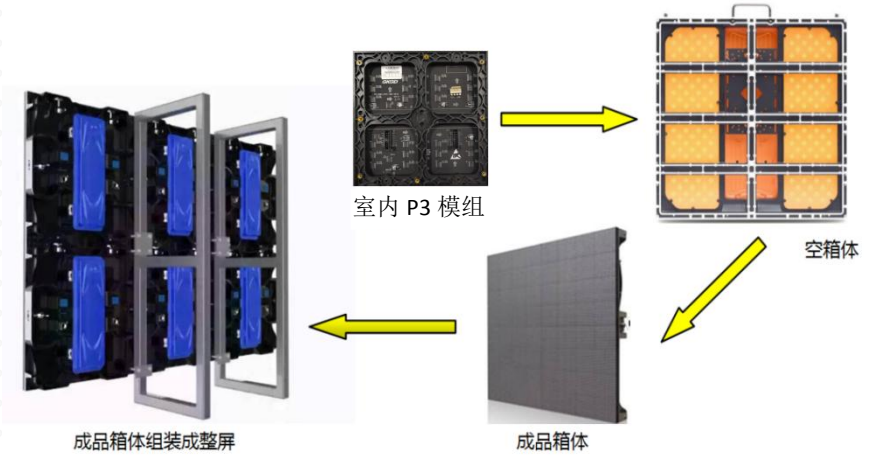

**Fixed Module Screw**

Use M4 screws to fix the module, and the length of the screws after passing through the box is  $\leq 5\text{mm}$ . Using GB9074.4 screws (as shown in the figure below, spring washers, washers and screws cannot be separated) can reliably fix the module. The box structure restricts the parts where GB9074.4 screws cannot be used, but GB818 screws can be used (see the figure below). Please refer to the corresponding national standard for screw selection and naming method.

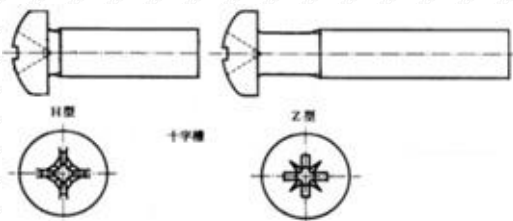

M4 GB818 Pan head screws

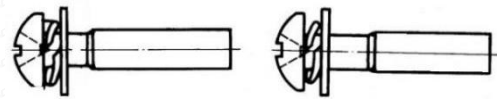

M4 GB9074.4 with locking screw

**Module Installation Clearance**

When the module is in use, the LED heats up, and the bottom case may expand slightly due to heat absorption. When installing the box,



pay attention to the splicing gap between the modules. The module installation gap is generally 0.2mm ~ 0.3mm. Pay attention to the opening of the box when processing and installing the module, and the spacing of the opening is reserved for the gap between the modules.

## **Magnetic Column Installation**

### **Magnetic Column Requirements**

The M4 magnetic column is commonly used in the LED display, and the diameter of the magnetic column chassis is  $13 \pm 0.05\text{mm}$ , the height of the magnetic column is  $13 \pm 0.05\text{mm}$ ; the diameter of the magnetic core is  $10 \pm 0.05\text{mm}$ , and the thickness of the magnetic core is  $1.2 \pm 0.05\text{mm}$ .

### **Module Magnetic Installation**

Design and manufacture the steel frame according to the size of the display screen and the size of the module, generally using  $40\text{mm} \times 40\text{mm}$  square steel. After the steel frame is installed on site, install the receiving card, power supply and wires on the steel frame. Install the magnetic column on the module, connect the power cable and the cable of the module, and magnetically attract the module to the steel frame as shown in the figure below.



建造固定模块的钢架



将磁柱安装在模块上



模块接线后磁吸在钢架上

## Module Signal Line Connection Method

There are two main ways to install signal cables: horizontal cascade and split connection. Horizontal cascading is that horizontal modules are connected by cables, and the rightmost module (the opposite module) is connected to the receiving card with a long cable.

The split connection is a way to make full use of the receiving card. As shown in the figure below, each row of modules is connected to the receiving card with a long cable. When there are many modules, the modules can continue to be expanded by horizontal cascading. Compared with the horizontal cascading method, the folio method can provide a higher refresh rate and a better display effect. When conditions permit, it should be connected in a split manner.

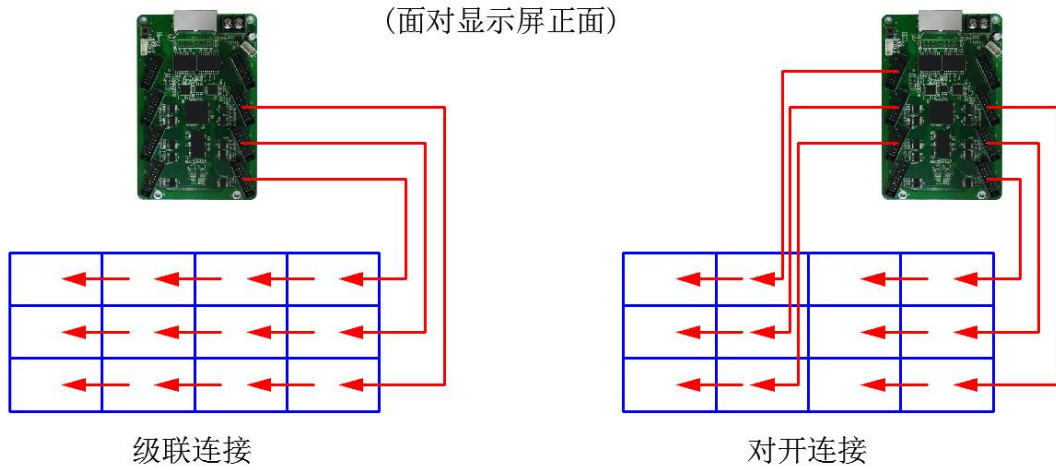

### Module Power Configuration

switching power supply	single module current	with the number of modules
5V 40A	2.9A (MAX)	≤10pcs

Note: The number of modules in the switching power supply should take into account the number of power interfaces

Power cord model: one for two 60cm-25cm/15cm VH4 crimped bar connection cable (pure copper or copper-clad aluminum).

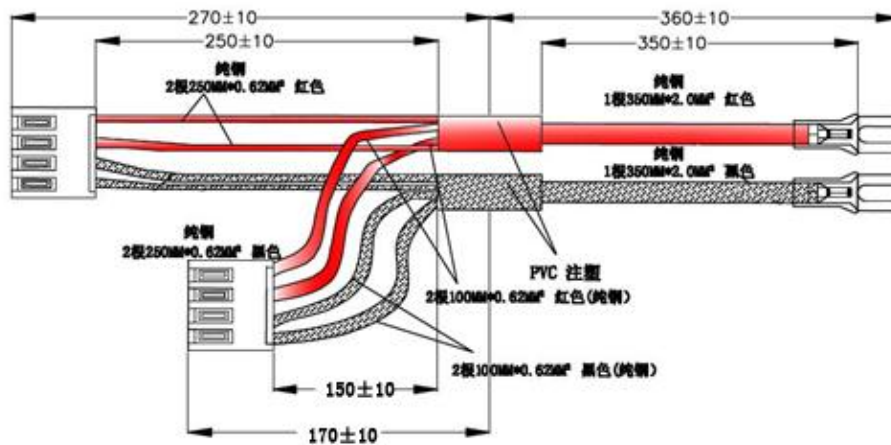

Schematic diagram of the power cord



The connection method of switching power supply is as follows

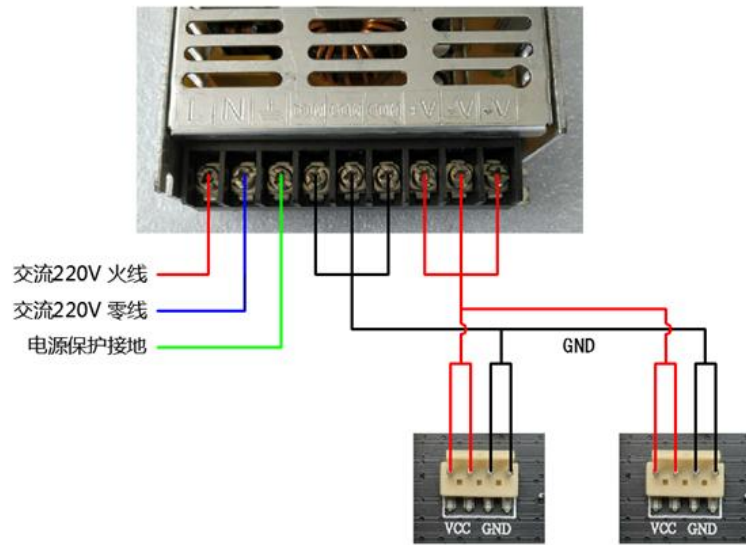

Power connection diagram

## Display Installation Method

### Wall Mount Installation

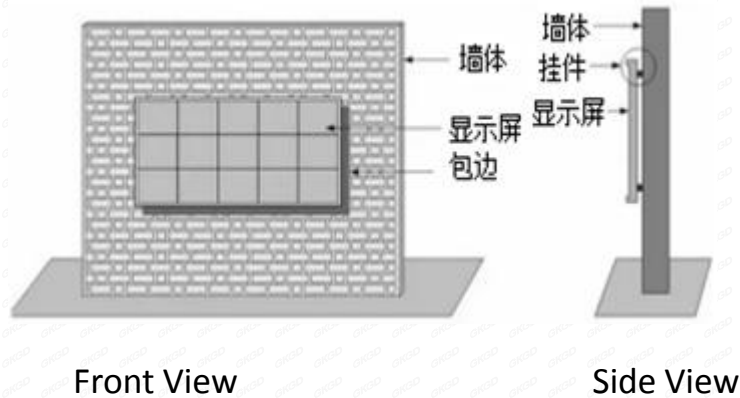

(1) This installation method is generally used for indoor wall advertisements, etc.

(2) When the screen area is small, generally no maintenance channel space is left, and the entire screen is removed for maintenance, or a foldable integrated frame is formed.

(3) When the screen area is large, the front maintenance method is generally



adopted.

## Frame Magnetic Strip Screen Installation



(1) Design the frame according to the installation area and the size of the module (considering the edging and splicing gap), the magnetic back strip is welded on the frame with 4cm wide square steel evenly arranged according to the size of the module, and finally the frame is fixed on the wall.

(2) M4 magnetic column is commonly used for LED display, the diameter of the magnetic column chassis is  $13 \pm 0.05\text{mm}$ , the height of the magnetic column is  $13 \pm 0.05\text{mm}$ ; the diameter of the magnetic core is  $10 \pm 0.05\text{mm}$ , and the thickness of the magnetic core is  $1.2 \pm 0.05\text{mm}$ .

(3) Larger display screens should be spliced with cabinets.

## Inlay Installation

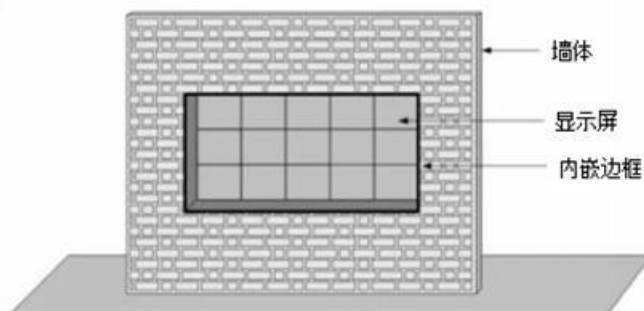

(1) The entire display body is embedded in the wall, and the display screen and the wall are in the same vertical plane perpendicular to the horizontal plane.

(2) The larger display screen should be spliced by the box body, and the smaller display screen can use the steel frame to install the module to save cost.

(3) The wall can be a solid wall with recessed space, or a decorative wall installed after the display screen is installed. For the solid wall, special attention should be paid to the design of the display screen heat dissipation air duct and waterproof and drainage.

### Seat Installation

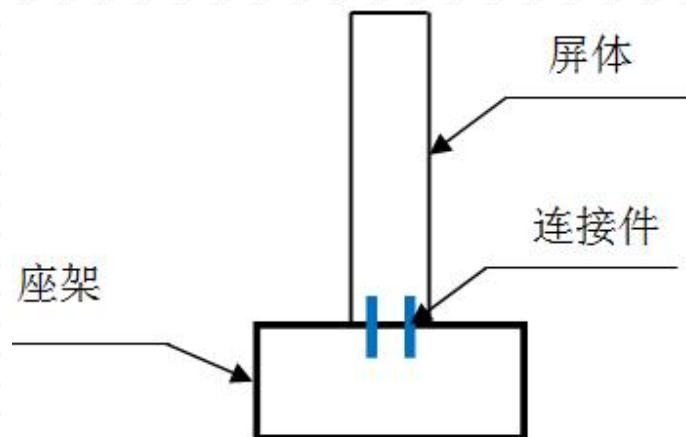

Removable seat: Refers to the seat frame is processed separately. It is placed on the ground and can be moved.

Fixed seat: Refers to the seat frame is a fixed seat frame connected to the ground or wall.

### Display Installation Precautions

#### Waterproof and Moistureproof

Before installing the display screen, you must check whether there is a hidden

danger of dripping water or serious moisture in the installation site of the display screen. If the display screen is wet or severely damp, it may cause a short circuit or even cause a failure and cause a fire.

It is required that the joint between the screen and the building must be strictly waterproof and leak-proof; the screen must have good drainage measures.

### **Ventilation and Cooling**

When the display screen is working, it will generate a certain amount of heat. If the ambient temperature is too high and the heat dissipation is poor, the integrated circuit may not work properly, or even be burned, so that the display system cannot work normally.

It is required to install ventilation equipment to cool down, so that the internal temperature of the screen is between  $-20\text{ }^{\circ}\text{C} \sim 50\text{ }^{\circ}\text{C}$ . A temperature-controlled fan is installed on the back of the screen to dissipate heat.

For installation methods that are difficult to repair and maintain, it is recommended to install remote monitoring and protection facilities.

### **Software Installation**

The display control and program production software, along with the software instruction manual, can be downloaded from the official website of the control system. Install and use the software according to the software instruction manual. If you have any questions about the use of the software, please consult our company's after-sales service or the control system manufacturer's after-sales service.

The receiving card program used by the control system can be downloaded from the official website of GKGD. Different module column driver ICs may require different versions of control and program production software, and may also need to upgrade the firmware of the receiving card to a specified version. Incorrect versions of control and program production software and receiving card firmware will result in abnormal display, or performance cannot be debugged to an ideal state. For specific requirements, please refer to the tips on the official website of GKGD or consult the after-sales service telephone of GKGD.

## Safety Requirements

### Module Usage Safety Requirements

### Installation Electrostatic Protection Requirements

Strict attention should be paid to electrostatic protection during the use of the LED module. Personnel who come into contact with the module must wear a grounded electrostatic wristband or electrostatic gloves.

### Installation Grounding Requirements

To prevent damage to chips or LEDs from lightning strikes or surges. During the module assembly process, various power tools must be well grounded, and the switching power supply shell and screen in the box must be properly grounded (must be separated from the strong electric ground).

### Module Cleaning Requirements

Cleaning the module requires using a clean soft rag moistened with alcohol to

gently wipe the surface of the module. Do not use chemical liquids with unknown functions to wipe, so as not to damage or corrode the plastic parts of the module, the LED casing or the LED lamp surface colloid. After cleaning, wait until the surface of the module is completely dry before powering on the display.

## Maintenance Requirements

When repairing the LED module, use a constant temperature electric soldering iron and air gun and ground it well. Soldering iron tips generally use knife-shaped soldering iron tips and conical soldering iron tips.

When soldering the drive surface components of the LED module, the temperature of the electric soldering iron is generally 290-320 ° C, the welding time cannot exceed 3s, and the number of soldering times is not more than three times. The gun is slightly swayed clockwise against the lamp bead. After the solder is completely melted, the maintenance operation is carried out, and the number of welding is not more than three times.



Knife Soldering Iron Tip



Conical Soldering Iron Tip

## Anti-collision Requirements

During the installation and transportation of the module, do not drop, push, squeeze, or press the package to prevent the module from falling and bumping, so as to avoid problems such as kit breakage, lamp beads falling off, lamp bead damage, pad falling off, and components falling off.

## Safety Requirements for Display Use

### Environment Temperature Requirements

In order to ensure the stable operation of the display screen and achieve the designed service life, the surface temperature of the module during operation is required to be  $\leq 85^{\circ}\text{C}$ , and the air temperature inside the display body is  $\leq 50^{\circ}\text{C}$ . According to the actual working environment of the display screen, take necessary cooling measures, such as adding exhaust fans and exhaust fans to form cooling air ducts or installing air conditioners for cooling.

### Display Content Requirements

In order to avoid serious attenuation of local LED lamp beads or dead lights, so that the display screen can reach the designed service life, it is not allowed to display still pictures or still texts for a long time, and must play scrolling pictures or texts.

### Power Connection Requirements

A dedicated switching power supply for LED display must be used. The total current of multiple modules connected to a single switching power supply cannot exceed 80% of the rated maximum output current of the power supply. The wires connecting the module and the power supply need to use high-quality copper wires, and ensure that the voltage  $U$  range at the module power socket is  $U \pm 0.2\text{V}$ .

When connecting the power supply, it must be noted that the module power socket corresponds to the positive and negative poles of the output terminal of the switching power supply. If the positive and negative poles are reversed, the module



will be burned, or even a fire will occur.

The module must not be connected to AC 220V, which will cause the module to burn immediately.

When wiring the power supply, make sure that the module plugs and sockets are connected reliably, and the terminal screws of the power socket of the switching power supply are tightened. Loose plugs, sockets and screws can lead to increased contact resistance causing wire burn or product damage.

## **Screen Acceptance Requirements and Methods**

### **Display Brightness Acceptance**

Adjust the display to full brightness, and use the brightness meter to measure the brightness of the display within 5 minutes. When measuring brightness, the optical axis of the luminance meter is required to be perpendicular to the screen body. Adjust the distance between the luminance meter and the display screen, make sure that the black dots or circles in the eyepiece of the luminance meter cover more than 16 pixels, adjust the focal length so that the LED lamp beads can be clearly seen in the eyepiece, and then measure and read the luminance data.

### **Visual Angle Acceptance**

As shown in the figure below, when viewing at 80° left and right of the screen and 70° from the lower viewing angle of the display, it is required that the screen has no obvious black spots and no obvious dark blocks.

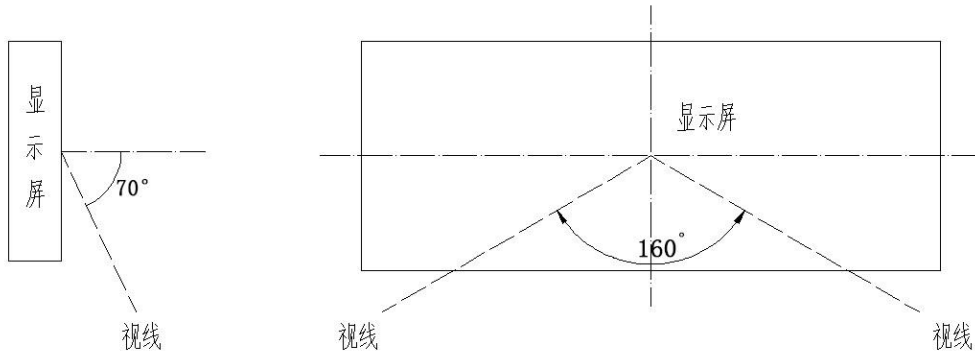

## Ground Check

The shell, box and display frame of the switching power supply must be well grounded, and the grounding resistance is required to be less than or equal to 10 ohms. Check the grounding resistance every six months.

## Lightning Protection Facility Inspection

The LED display screen is required to be reliably grounded, the power distribution box is required to be equipped with a surge protector, and the lightning protection facilities are checked every six months. Avoid using the display during thunderstorms.

## Anti-burn-in Operation Requirements

### Standard Operation

When the entire screen is powered off, connect the signal cable and power cable, check the connection is good, and then power on the entire screen. If the display is found to be bad, immediately power off the entire screen, and then rectify the wiring and then power on the entire screen for inspection.

## **Live Installation Operation**

When live installation is required, it must be operated in the following order: first connect the signal input cable, then connect the signal output cable, and finally connect the module power plug. The modules must be installed and debugged one by one, and it is not allowed to continuously install multiple modules with abnormal display and then debug.

## **The display is abnormal when the whole screen is used**

If the user finds that the display is abnormal during use, especially if the whole line is highlighted, the whole screen should be repaired immediately after the power is turned off, so as to avoid power supply for a long time in this situation.

## **After-sales service contact information**

Phone : 400-101-6001

Postcode : 046000

Email : gkgd@gkgd.com

Website : www.gkgd.com

Address : No. 15, West Section of Huifeng Street, Luzhou District, Changzhi City